

Teknisk specifikation

SIS-CEN/TS 17342:2019

Publicerad/Published: 2019-09-20

Utgåva/Edition: 1

Språk/Language: engelska/English

ICS: 13.200;93.080.30

Vägutrustning – Skyddsanordningar – Skyddsanordningar som reducerar allvarligheten när motorcyklister kolliderar med skyddsräcken

Road restraint systems – Motorcycle road restraint systems which reduce the impact severity of motorcyclist collisions with safety barriers

© SIS, Swedish Standards Institute. Detta är ett personligt arbetsexemplar med enanvändarlicens från SIS projektledare Peter Claeson för Dig som deltagare i SIS/TK 248. Kopiering och/eller spridning av hela eller delar av innehållet i dokumentet är inte tillåtet. 2019-10-04.

© SIS, Swedish Standards Institute. This is a personal copy for participants with a single user license from SIS project manager Peter Claeson for you in your capacity as participant in SIS/TK 248. Copying and/or distribution of the content of the standard, in whole or in part, is not allowed. 2019-10-04.

Standarder får världen att fungera

SIS (Swedish Standards Institute) är en fristående ideell förening med medlemmar från både privat och offentlig sektor. Vi är en del av det europeiska och globala nätverk som utarbetar internationella standarder. Standarder är dokumenterad kunskap utvecklad av framstående aktörer inom industri, näringsliv och samhälle och befrämjar handel över gränser, bidrar till att processer och produkter blir säkrare samt effektiviserar din verksamhet.

Delta och påverka

Som medlem i SIS har du möjlighet att påverka framtida standarder inom ditt område på nationell, europeisk och global nivå. Du får samtidigt tillgång till tidig information om utvecklingen inom din bransch.

Ta del av det färdiga arbetet

Vi erbjuder våra kunder allt som rör standarder och deras tillämpning. Hos oss kan du köpa alla publikationer du behöver – allt från enskilda standarder, tekniska rapporter och standardpaket till handböcker och onlinetjänster. Genom vår webbtjänst e-nav får du tillgång till ett lättnavigerat bibliotek där alla standarder som är aktuella för ditt företag finns tillgängliga. Standarder och handböcker är källor till kunskap. Vi säljer dem.

Utveckla din kompetens och lyckas bättre i ditt arbete

Hos SIS kan du gå öppna eller företagsinterna utbildningar kring innehåll och tillämpning av standarder. Genom vår närhet till den internationella utvecklingen och ISO får du rätt kunskap i rätt tid, direkt från källan. Med vår kunskap om standarders möjligheter hjälper vi våra kunder att skapa verklig nytta och lönsamhet i sina verksamheter.

Vill du veta mer om SIS eller hur standarder kan effektivisera din verksamhet är du välkommen in på www.sis.se eller ta kontakt med oss på tel 08-555 523 00.

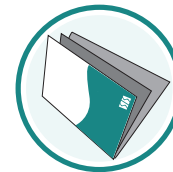

Standards make the world go round

SIS (Swedish Standards Institute) is an independent non-profit organisation with members from both the private and public sectors. We are part of the European and global network that draws up international standards. Standards consist of documented knowledge developed by prominent actors within the industry, business world and society. They promote cross-border trade, they help to make processes and products safer and they streamline your organisation.

Take part and have influence

As a member of SIS you will have the possibility to participate in standardization activities on national, European and global level. The membership in SIS will give you the opportunity to influence future standards and gain access to early stage information about developments within your field.

Get to know the finished work

We offer our customers everything in connection with standards and their application. You can purchase all the publications you need from us - everything from individual standards, technical reports and standard packages through to manuals and online services. Our web service e-nav gives you access to an easy-to-navigate library where all standards that are relevant to your company are available. Standards and manuals are sources of knowledge. We sell them.

Increase understanding and improve perception

With SIS you can undergo either shared or in-house training in the content and application of standards. Thanks to our proximity to international development and ISO you receive the right knowledge at the right time, direct from the source. With our knowledge about the potential of standards, we assist our customers in creating tangible benefit and profitability in their organisations.

If you want to know more about SIS, or how standards can streamline your organisation, please visit www.sis.se or contact us on phone +46 (0)8-555 523 00



Denna tekniska specifikation är inte en svensk standard. Detta dokument innehåller den engelska språkversionen av CEN/TS 17342:2019.

Detta dokument ersätter SIS-CEN/TS 1317-8:2012, utgåva 1.

This Technical Specification is not a Swedish Standard. This document contains the English language version of CEN/TS 17342:2019.

This document supersedes SIS-CEN/TS 1317-8:2012, edition 1.

© Copyright/Upphovsrätten till denna produkt tillhör SIS, Swedish Standards Institute, Stockholm, Sverige. Användningen av denna produkt regleras av slutanvändarlicensen som återfinns i denna produkt, se standardens sista sidor.

© Copyright SIS, Swedish Standards Institute, Stockholm, Sweden. All rights reserved. The use of this product is governed by the end-user licence for this product. You will find the licence in the end of this document.

Uppllysningar om sakinnehållet i detta dokument lämnas av SIS, Swedish Standards Institute, telefon 08-555 520 00. Standarder kan beställas hos SIS som även lämnar allmänna upplysningar om nationell och internationell standard.

Information about the content of this document is available from the SIS, Swedish Standards Institute, telephone +46 8 555 520 00. Standards may be ordered from SIS, who can also provide general information about national and international standards.

Dokumentet är framtaget av kommittén för Vägutrustning, SIS/TK 248.

Har du synpunkter på innehållet i det här dokumentet, vill du delta i ett kommande revideringsarbete eller vara med och ta fram standarder inom området? Gå in på www.sis.se - där hittar du mer information.

ARBETSEXEMPLAR SIS/
WORK COPY SIS/

TECHNICAL SPECIFICATION

CEN/TS 17342

SPÉCIFICATION TECHNIQUE

TECHNISCHE SPEZIFIKATION

June 2019

ICS 13.200; 93.080.30

Supersedes CEN/TS 1317-8:2012

English Version

Road restraint systems - Motorcycle road restraint systems which reduce the impact severity of motorcyclist collisions with safety barriers

Dispositifs de retenue routiers - Dispositifs de retenue routiers pour motos réduisant la sévérité de choc en cas de collision de motocyclistes avec les barrières de sécurité

Rückhaltesysteme an Straßen - Rückhaltesysteme für Motorräder, die die Anprallheftigkeit an Schutzplanken für Motorradfahrer reduzieren

This Technical Specification (CEN/TS) was approved by CEN on 15 April 2019 for provisional application.

The period of validity of this CEN/TS is limited initially to three years. After two years the members of CEN will be requested to submit their comments, particularly on the question whether the CEN/TS can be converted into a European Standard.

CEN members are required to announce the existence of this CEN/TS in the same way as for an EN and to make the CEN/TS available promptly at national level in an appropriate form. It is permissible to keep conflicting national standards in force (in parallel to the CEN/TS) until the final decision about the possible conversion of the CEN/TS into an EN is reached.

CEN members are the national standards bodies of Austria, Belgium, Bulgaria, Croatia, Cyprus, Czech Republic, Denmark, Estonia, Finland, Former Yugoslav Republic of Macedonia, France, Germany, Greece, Hungary, Iceland, Ireland, Italy, Latvia, Lithuania, Luxembourg, Malta, Netherlands, Norway, Poland, Portugal, Romania, Serbia, Slovakia, Slovenia, Spain, Sweden, Switzerland, Turkey and United Kingdom.



EUROPEAN COMMITTEE FOR STANDARDIZATION
COMITÉ EUROPÉEN DE NORMALISATION
EUROPÄISCHES KOMITEE FÜR NORMUNG

CEN-CENELEC Management Centre: Rue de la Science 23, B-1040 Brussels

SIS-CEN/TS 17342:2019 (E)

Contents		Page
European foreword		4
Introduction		5
1	Scope	6
2	Normative references	6
3	Terms and definitions	6
4	Symbols and abbreviations	7
5	Biomechanical indices for assessing the impact severity of a PTW rider against an MPS	8
5.1	General	8
5.2	Index representing the head injury risk: Head injury criterion (HIC36)	8
5.3	Indices representing neck injury risk	8
6	Test methods	9
6.1	General	9
6.2	Test site	9
6.3	Propulsion system	10
6.4	ATD and instrumentation	10
6.5	ATD clothing and equipment	11
6.5.1	Helmet	11
6.5.2	Clothing	11
6.6	ATD mass including equipment	11
6.7	Installation	11
6.8	Impact conditions	12
6.9	Launch configurations	12
6.9.1	General	12
6.9.2	Launch configuration 1: post-centred impact	13
6.9.3	Launch configuration 2: post offset impact	13
6.9.4	Launch configuration 3: mid-span impact	14
6.10	Accuracies and deviation of impact speeds and angles	15
6.10.1	ATD impact speed	15
6.10.2	ATD approach angle	15
6.10.3	ATD orientation	16
6.10.4	ATD impact point	16
6.11	Photographic coverage	16
7	Performance classes	17
7.1	General	17
7.2	Speed classes	18
7.3	Severity levels	18
7.4	Deformation of the CMPS	23
8	Acceptance criteria of the impact test	23
8.1	MPS behaviour	23
8.2	ATD behaviour	23
8.3	Severity indices	25
8.4	Vehicle impact performance	25

9	Test report	25
	Annex A (informative) Detailed report template	26
	Annex B (informative) Anthropomorphic test device	31
	Annex C (informative) Helmet alignment tool	33
	Annex D (informative) Modification of the anthropomorphic test device shoulder	35
	Annex E (informative) Reference helmet	43
	Annex F (informative) Helmet calibration procedure	44
F.1	General	44
F.2	Helmet description	44
F.3	Procedure description and layout	44
F.4	Helmet assessment	45
	Bibliography	47

ARBETSEXEMPLAR SIS/
WORK COPY SIS/

SIS-CEN/TS 17342:2019 (E)

European foreword

This document (CEN/TS 17342:2019) has been prepared by Technical Committee CEN/TC 226 "Road equipment", the secretariat of which is held by AFNOR.

Attention is drawn to the possibility that some of the elements of this document may be the subject of patent rights. CEN shall not be held responsible for identifying any or all such patent rights.

This document supersedes CEN/TS 1317-8:2012.

The significant technical changes incorporated in this revision are updates of the European foreword, the Scope and Subclause 6.2, *Test site*.

CEN/TS 1317-8 needed to be brought into line with EN 1317 in development (merging of EN 1317-1:2010, EN 1317-2:2010, EN 1317-3:2010, EN 1317-5, EN 1317-7 and additional test methods for removable barrier sections).

According to the CEN/CENELEC Internal Regulations, the national standards organisations of the following countries are bound to announce this Technical Specification: Austria, Belgium, Bulgaria, Croatia, Cyprus, Czech Republic, Denmark, Estonia, Finland, Former Yugoslav Republic of Macedonia, France, Germany, Greece, Hungary, Iceland, Ireland, Italy, Latvia, Lithuania, Luxembourg, Malta, Netherlands, Norway, Poland, Portugal, Romania, Serbia, Slovakia, Slovenia, Spain, Sweden, Switzerland, Turkey and the United Kingdom.

ARBETSEXEMPLAR
WORK COPY SIS

Introduction

In order to improve safety, the design of roads may require the installation of road restraint systems, which are intended to contain and redirect errant vehicles safely for the benefit of the occupants and other road users, or pedestrian parapets designed to restrain and to guide pedestrians and other road users not using vehicles, on sections of road and at particular locations defined by the national or local authorities.

EN 1317-2 contains performance classes, impact test acceptance criteria and test methods for barriers. Whereas EN 1317-2 covers the performance of these systems with respect to cars and heavy vehicles, this document addresses the safety of the riders of powered two-wheeled vehicles impacting the barrier having fallen from their vehicle.

As powered two-wheeler riders may impact a barrier directly (in which case no protection is offered by the vehicle), special attention is given to these vulnerable road-users. In order to minimize the consequences to a rider of such an impact, it may be necessary to fit a barrier with a specific PTW rider protection system. Alternatively, a barrier might specifically incorporate characteristics limiting the consequences of a PTW rider impact.

Rider protection systems may be continuous (including barriers specifically designed with the safety of PTW riders in mind) or discontinuous. A discontinuous system is one which offers rider protection in specific localized areas of a barrier judged to be of higher risk. The most common example of a discontinuous system is one fitted locally to the posts of a post and rail type guardrail - adding nothing between the posts.

The purpose of this document is to define the terminology specific to it, to describe procedures for the initial type-testing of rider protection systems and to provide performance classes and acceptance criteria for them.

Accident statistics from several European countries have shown that riders are injured when impacting barriers either whilst still on their vehicles or having fallen and then sliding along the road surface. Whilst different statistical sources show one or the other of these configurations to be predominant, all known studies show both to constitute a major proportion of rider to barrier impact accidents. Some studies showing the sliding configuration to be predominant have led to the development and use of test procedures in some European countries, evaluating systems with respect to the sliding configuration. At the time of writing, a number of such protection systems were already on the European market. It is for this reason that it was decided to address the issue of sliding riders initially, in order to bring about the adoption of a European Standard in as timely a manner as possible. However, the rider on vehicle configuration should also be considered as soon as possible as a subsequent addition.

This document will be read in conjunction with EN 1317-1 and EN 1317-2.

SIS-CEN/TS 17342:2019 (E)

1 Scope

This document specifies requirements for the impact performance of systems designed for the reduction of impact severity for PTW riders impacting safety barriers whilst sliding along the ground, having fallen from their PTW vehicle. The protection systems concerned are those fitted to barriers or barriers that have an inherent PTW rider protection or risk reduction capability. This document excludes the assessment of the vehicle restraint capabilities of barriers and the risk that they represent to the occupants of impacting cars. The assessment of barrier performance with respect to impacting vehicles is covered by EN 1317-1 and EN 1317-2.

This document defines performance classes taking into account rider speed classes, impact severity and the working width of the system with respect to rider impacts.

For systems designed to be added to a standard barrier, the test results are valid only when the system is fitted to the model of barrier used in the tests since the performance will not necessarily be the same if the system is fitted to a different barrier.

2 Normative references

The following documents are referred to in the text in such a way that some or all of their content constitutes requirements of this document. For dated references, only the edition cited applies. For undated references, the latest edition of the referenced document (including any amendments) applies.

EN 1317-2¹, *Road restraint systems – Part 2: Performance classes, impact test acceptance criteria and test methods for safety barriers including vehicle parapets*

EN 1621-1, *Motorcyclists' protective clothing against mechanical impact – Part 1: Motorcyclists' limb joint impact protectors – Requirements and test methods*

ISO 6487, *Road vehicles – Measurement techniques in impact tests – Instrumentation*

3 Terms and definitions

For the purposes of this document, the following terms and definitions apply.

ISO and IEC maintain terminological databases for use in standardization at the following addresses:

- IEC Electropedia: available at <http://www.electropedia.org/>
- ISO Online browsing platform: available at <http://www.iso.org/obp>

3.1 biomechanical indices

indices obtained from the registers measured in the ATD, which are used to evaluate the severity of the impact

3.2 clothing

see 6.5.2

¹ Under revision.

3.3

continuous motorcyclist protection system

MPS placed continuously along a barrier with the purpose of retaining and redirecting an impacting rider, usually preventing direct impact with aggressive elements of the barrier such as posts, anchorages or module connections, and that also prevents a sliding rider from passing between the posts of a barrier and coming into contact with any potential hazard that may be behind the barrier

3.4

discontinuous motorcyclist protection system

MPS placed locally around a potentially aggressive element of a barrier, such as a post, anchorage or module connection, with the purpose of reducing the severity of a direct impact of the rider against it

Note 1 to entry: This type of system is not intended to contain fallen PTW riders since the system is not present continuously along the length of the barrier.

3.5

dummy working width

W_d

distance between the foremost part of the un-deformed system and the maximum dynamic lateral position of any part of the system or ATD

Note 1 to entry: See 7.4.

3.6

impact severity

risk level of physical injury to a rider resulting from an impact

3.7

integrated motorcyclist protection system

motorcyclist protection system, either continuous or discontinuous, which forms an integral part of a barrier design rather than being a separate add-on fitted to an existing barrier

3.8

helmet

see 6.5.1

3.9

motorcyclist

rider of any powered two-wheeler

3.10

motorcyclist protection system

device installed on a barrier or in its immediate surroundings, the purpose of which is to reduce the severity of a PTW rider impact against the barrier

4 Symbols and abbreviations

For the purposes of this document, the following abbreviations apply.

CMPS Continuous Motorcyclist Protection System

DMPS Discontinuous Motorcyclist Protection System

MPS Motorcyclist Protection System

SIS-CEN/TS 17342:2019 (E)

PTW Powered Two-Wheeler

W_d Dummy working width

5 Biomechanical indices for assessing the impact severity of a PTW rider against an MPS

5.1 General

In order to assess the severity and define the acceptance criteria, the following biomechanical indices shall be used.

The sign convention shown in Figure 1² shall be adopted.

5.2 Index representing the head injury risk: Head injury criterion (HIC36)

The Head Injury Criterion (HIC36) is an acceleration-based criterion defined by Formula (1):

$$HIC = \max \left[\frac{1}{t_2 - t_1} \times \int_{t_1}^{t_2} a \times dt \right]^{2,5} \times (t_2 - t_1) \quad (1)$$

where

a is the resultant acceleration at the centre of gravity of the head expressed as units of gravity (1 g = 9,81 m/s²)

$$a = \sqrt{a_x^2 + a_y^2 + a_z^2} \quad (2)$$

a_x is the acceleration X-axis;

a_y is the acceleration Y-axis;

a_z is the acceleration Z-axis.

The (HIC36) values for calculation intervals ($t_2 - t_1$) greater than 36 are not taken into account for the calculation of maximum values, i.e. $(t_2 - t_1) \leq 36$ ms.

5.3 Indices representing neck injury risk

The indices representing neck injury risk are:

- anterior-posterior shear force (F_x),
- lateral shear force (F_y),
- tension-compression force (F_z),
- lateral bending moment calculated about the occipital condyle (M_{oc_x}),
- flexion/extension moment calculated about the occipital condyle (M_{oc_y}),
- torsion moment (M_z).

² According to SAE J1733.

The above indices shall be determined using the “upper neck load cell”.

The moments about the occipital condyles M_{oc_x} and M_{oc_y} are calculated from the moments M_x and M_y expressed in Nm and the forces F_x and F_y expressed in N according to the expressions:

$$M_{oc_x} = M_x + F_y \times D \quad (3)$$

$$M_{oc_y} = M_y - F_x \times D \quad (4)$$

where

M_x is the lateral bending moment on the neck;

M_y is the flexion/extension moment on the neck;

D is the distance for the transfer to the occipital condyle of the moments of bending measured. It shall adopt the specific value mentioned in 6.4.

The types of movement resulting in positive values of neck forces and moments are:

- $+F_x$: head backwards, chest forward (forward-backward shear),
- $+F_z$: head upwards, chest downward (traction),
- $+M_x$: left ear towards left shoulder (lateral bending),
- $+M_y$: chin towards sternum (flexion).

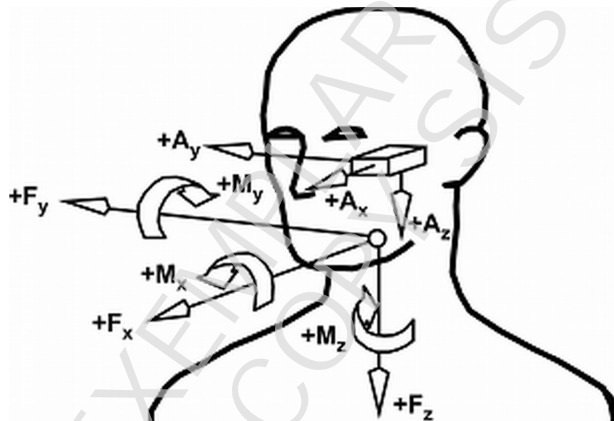

Figure 1 — Sign convention for accelerations, forces and moments in the ATD

6 Test methods

6.1 General

The full-scale impact test consists of launching an ATD at a given speed against a barrier with MPS (or integrated system), in a suitable test area. At the moment of impact, the ATD is sliding with its back and legs stably in contact with the ground.

6.2 Test site

The test area, including all areas over which the ATD is displaced during the test and the ground under any part of the test installation, shall be generally flat with a gradient not exceeding 2,5 %. The test area shall be clear of dust, debris, standing water, ice and snow at the time of the test in the entire area over which the ATD is displaced during the test. No part of the test item shall be in contact with any ice or snow that could modify the deformation or performance of the test item during the test.

SIS-CEN/TS 17342:2019 (E)

The test zone shall have a level hardened paved surface in the area on which the ATD is launched and along the traffic side of the test installation over an area sufficient to incorporate the entire ATD trajectory of the test. The test zone shall incorporate a smooth area along the approach path of the ATD to facilitate sliding of the ATD before impact.

A dimensioned sketch plan(s) of the test area shall be included in the test report which shall show the testing area including the test installation (including barrier), position of all cameras, path of the ATD, impact point and the dimensioned locations for all test item parts exceeding 2,0 kg that broke away during the test.

The dimensions of the edge detail shall be sufficient to demonstrate the actual performance of the vehicle and the tested system on the edge of a bridge, or structure.

The test shall demonstrate the minimum width of structure behind the traffic face of the vehicle parapet that is required to safely contain a PTW rider.

Appropriate measures shall be taken in order to minimize dust generation from the test area and the test vehicle during the impact test so that photographic records will not be obscured.

Appropriate measures shall be taken to ensure that in the exit area, and during the impact, the ATD does not make contact with any independent obstruction which could have an effect on the ATD interaction with the test item or the ATD trajectory.

6.3 Propulsion system

The ATD shall not be restrained, other than by the friction of the paved surface, guided or propelled by any force external to it at the point of impact.

6.4 ATD and instrumentation

The ATD used for the tests shall be a modified Hybrid III 50th percentile male ATD as described and according to the conditions of use given in Annex B.

All necessary measurements to evaluate the biomechanical indices shall be carried out with measurement systems compliant with ISO 6487.

The resultant acceleration measured at the centre of gravity of the ATD's head shall be calculated from the tri-axial components of the acceleration recorded with Channel Frequency Class 1 000 (CFC 1 000) and a Channel Amplitude Class of 500 g (CAC 500 g).

The neck forces and moments shall be measured by a six-channel upper neck load cell specifically designed to be fitted to the Hybrid III ATD. These forces and moments shall be recorded as follows:

- F_x and F_y with a CAC of 8 kN and a CFC of 1 000,
- F_z with a CAC of 13 kN and a CFC of 1 000;
- M_x , M_y and M_z with a CAC of 280 N m and a CFC of 600.

For the transfer of moments measured by the neck load cell to the occipital condyle, both the forces and moments shall have a CFC of 600.

For the distance D, the value of 0,017 78 m shall be adopted for those load cells installed in the existing space at the base of the skull and 0,008 763 m for those load cells mounted on the lower surface of the base of the skull.

An event indicator shall be used to signal the moment of first ATD contact with the test item. However, the method used shall not modify the ATD to test item contact (e.g. the use of a tape switch on the helmet is not acceptable).

6.5 ATD clothing and equipment

6.5.1 Helmet

The ATD shall be equipped with an integral type, production motorcycle helmet weighing $1,300 \text{ kg} \pm 0,050 \text{ kg}$ and with a polycarbonate shell. A reference helmet model is given in Annex E. The helmet shall meet the specifications given in Annex F. Annex E gives alternative helmet models that have been found to meet the requirements in Annex F.

NOTE In all cases, the helmet used will comply with the requirements set out in Regulation 22 of ECE/TRANS/505.

The surface of the helmet in contact with the test item shall be smooth, and free from protruding parts, vents, roughness or any other kind of unevenness, so that the contact conditions between the helmet and the test item are not influenced by any such feature.

The helmet shall be new for each test. No alteration of the original production helmet shall be undertaken. No stickers, paint or any other item or substance shall be applied to the helmet in any area of its surface which will be in contact with the test item.

The helmet shall be fitted onto the head of the ATD in accordance with Annex C. If helmet models other than those given in Annex E are used, the size shall be chosen in order to ensure that the fit of the helmet on the ATD head is as snug as possible, with the helmet held firmly onto the head.

Care should be taken to choose a helmet that will leave visible traces on the test item during contact, i.e. helmet with paint of a colour which contrasts with the test item colour.

6.5.2 Clothing

The ATD shall be dressed in a long-sleeved cotton t-shirt to be worn under a leather, one-piece motorcycle suit (or two-piece suit if the two pieces are joined together) conforming to EN 1621-1, leather gloves, and leather boots. The leather suit shall not be fitted with any additional protection devices (e.g. back supports or neck restraints) or features that influence the behaviour of the ATD or restrict the movement of its limbs any more than would be the case with a simple leather suit.

The sizes of all items of clothing shall be appropriate so as to fit the ATD correctly.

The upper and lower extremities shall be clearly visually identified by painting the clothing, boots and gloves using a paint colour contrasting with the test zones surroundings. Each lower extremity shall be identified by painting the trouser leg and boot from the knee down. Each upper extremity shall be identified by painting the sleeve, and if necessary part of the glove, from the centre of the elbow joint to the centre of the wrist joint.

There shall be a clear, visible distinction between the hand (from the wrist joint to the fingertips) and the rest of the upper extremity.

6.6 ATD mass including equipment

The total test ATD mass, including instrumentation, helmet, shirt, suit, gloves and boots, shall be $87,50 \text{ kg} \pm 2,50 \text{ kg}$.

6.7 Installation

For continuous systems, the length of the test item shall be sufficient to demonstrate the full performance characteristics of the MPS. After the test, the adequacy of the length of installation shall be checked by determining whether there is any permanent lateral or longitudinal displacement of the test item at its extremities.

Any end conditions (for example end anchorages) of the barrier or integrated MPS shall be identical to those used in the vehicle impact tests performed on the same barrier according to EN 1317-2. Any fixings

SIS-CEN/TS 17342:2019 (E)

(for example fixing of a CMPS to a barrier) of the MPS, or end conditions of a CMPS, shall be provided in accordance with the design of the MPS.

For DMPS, the minimum installation length of the supporting barrier shall be determined by the test house and agreed to by the manufacturer before the test. A minimum of two DMPS shall be installed on consecutive posts (or whichever other element supports the DMPS): one corresponding with the impact point and the other downstream of the impact.

Foundations for the test item shall meet the design specification.

When testing pretensioned MPSs, for which tension can be adjusted, any measurable applied tension or torque shall conform to that which is specified in the MPS installation manual and shall be recorded in the test report.

The height above the ground of the lower edge of the elements designed to restrain the PTW rider shall be measured in the impact zone and noted in the test report

NOTE This distance can influence the capacity of the system to restrain a rider.

6.8 Impact conditions

The full-scale impact tests are carried out by launching an ATD against the test item (in the case of a CMPS, against a straight length of test item) in accordance with a determined approach path and test conditions.

At the moment of the initial impact of the ATD against the test item, the surfaces of the helmet and the test item in the impact area shall be clean, dry, and free of any item or substance that may affect the contact between both surfaces.

The ATD shall impact the test item at a point approximately at the mid-point along the length of the test item or, in the case of a DMPS fitted to a barrier, approximately at the mid-point of the barrier. The exact position of the impact along the length of the test item shall be chosen by the test house in order to demonstrate the most severe impact conditions and the choice shall take into account any potentially hazardous feature of the test item.

The test shall be deemed to be completed when, following the impact (or impacts) the ATD has come completely to rest. Any secondary impacts, including any with the ground or hardened test zone surface, occurring before the ATD comes to rest shall be considered when determining the test results. If the ATD is connected to the data acquisition system by an umbilical cable, the ATD may be arrested to avoid damage occurring to the umbilical cable. Any such arresting of the ATD shall take place once the ATD is no longer in contact with the test item, after all injury criterion measurements have started to decrease or after any event resulting in a negative test result for the test item.

6.9 Launch configurations

6.9.1 General

Three theoretical approach paths are defined as below. If the test laboratory judges that the impact point identified in this document for a given test is not representative of the most severe testing conditions, the laboratory may change the impact point accordingly. In all cases, the impact point shall be identified in the test report its choice justified.

For each configuration, the ATD shall be launched lying face-up in a "supine decubitus" position, i.e. face up in a horizontal position and completely stretched out on its back, with its upper limbs parallel and adjacent to its trunk, with the palms of its hands oriented towards its trunk. The longitudinal centreline of the ATD spine shall coincide with the direction of the approach path and the head shall be oriented towards the theoretical impact point.

6.9.2 Launch configuration 1: post-centred impact

The approach path of the ATD is defined by a line, parallel to the ground, passing through the centre (O) of the post section and forming a 30° angle with respect to the centreline of the un-deformed test item (see Figure 2). For a CMPS, if the test item is not, or is not fitted to, a post-and-rail type safety barrier, point O shall be the centre of an anchorage, a connection between elements of the test item or any other point deemed to result in the highest severity impact. For a DMPS, point O is the centre of the item onto which the MPS is fitted.

This launch configuration is applicable to all types of MPS and, is generally intended to represent the configuration resulting in the most severe impact-related injuries.

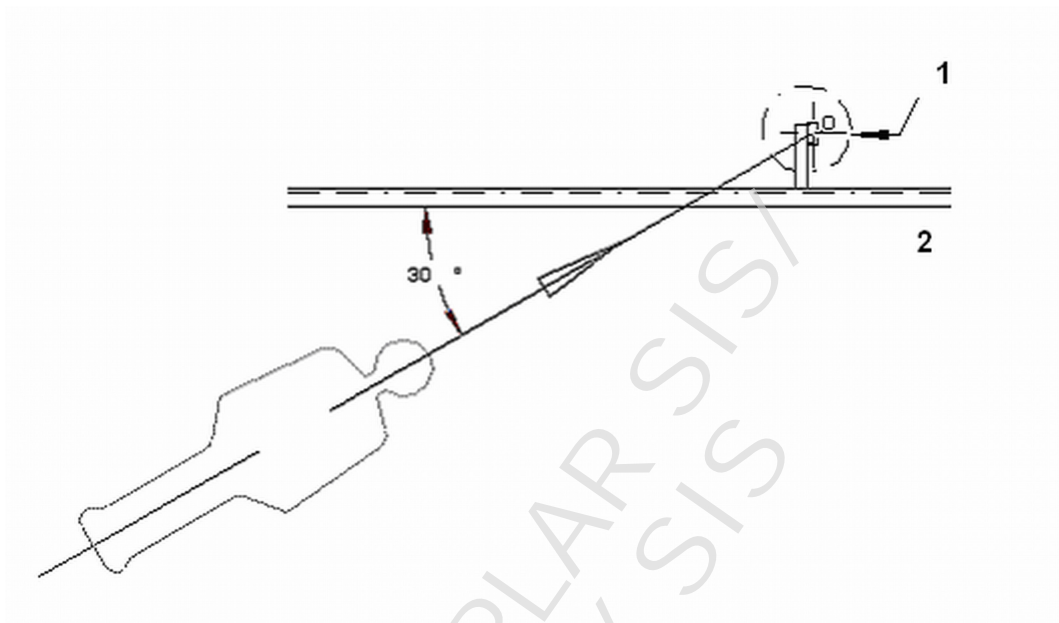

Key

- 1 discontinuous system
- 2 continuous system

Figure 2 — Launch configuration 1: post-centred impact

6.9.3 Launch configuration 2: post offset impact

The approach path of the ATD is defined by a line parallel to the ground and parallel to a line at 30° to the centreline of the un-deformed test item, passing through the point O (centre of the post section). The approach path shall be 20 cm upstream of the 30° line passing through point O (see Figure 3).

This configuration is only applicable when the test item is a DMPS. If the test item is not fitted to a post-and-rail type safety barrier, point O shall be the centre of the item onto which the MPS is fitted.

The purpose of this configuration is to impact the edge of the DMPS which may be potentially aggressive and/or to achieve maximal deceleration of the ATD.

SIS-CEN/TS 17342:2019 (E)

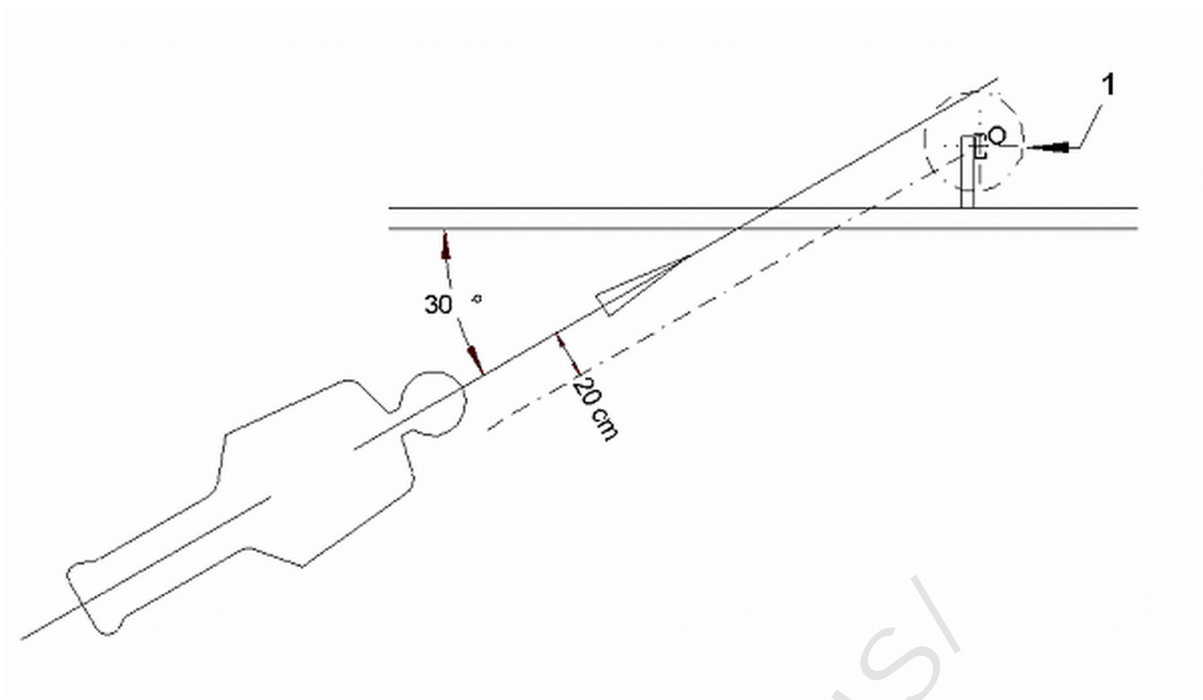

Key

1 discontinuous system

Figure 3 — Launch configuration 2: post-offset impact

6.9.4 Launch configuration 3: mid-span impact

The approach path of the ATD is defined by a line, parallel to the ground, passing through point I and forming a 30° angle with respect to the centreline of the un-deformed test item (see Figure 4). Point I is the intersection of the surface in contact with ATD during the test and the perpendicular bisector of the segment joining points O_n and O_{n+1} (see Figure 4). Points O_n and O_{n+1} are the centres of the sections of two consecutive posts of the barrier. If the system is not a post-and-rail type safety barrier, points O_n and O_{n+1} shall be the centres of two consecutive anchorages or element connections of the test item or any other point deemed to result in the highest severity impact.

This launch configuration is only applicable to CMPS and is primarily intended to test the robustness of the test item where it is most flexible and to evaluate the potential for the trapping of limbs in the area where this is most likely to occur. However, in some cases, the injury criteria values measured on the ATD may be higher for this configuration than for Configuration 1.

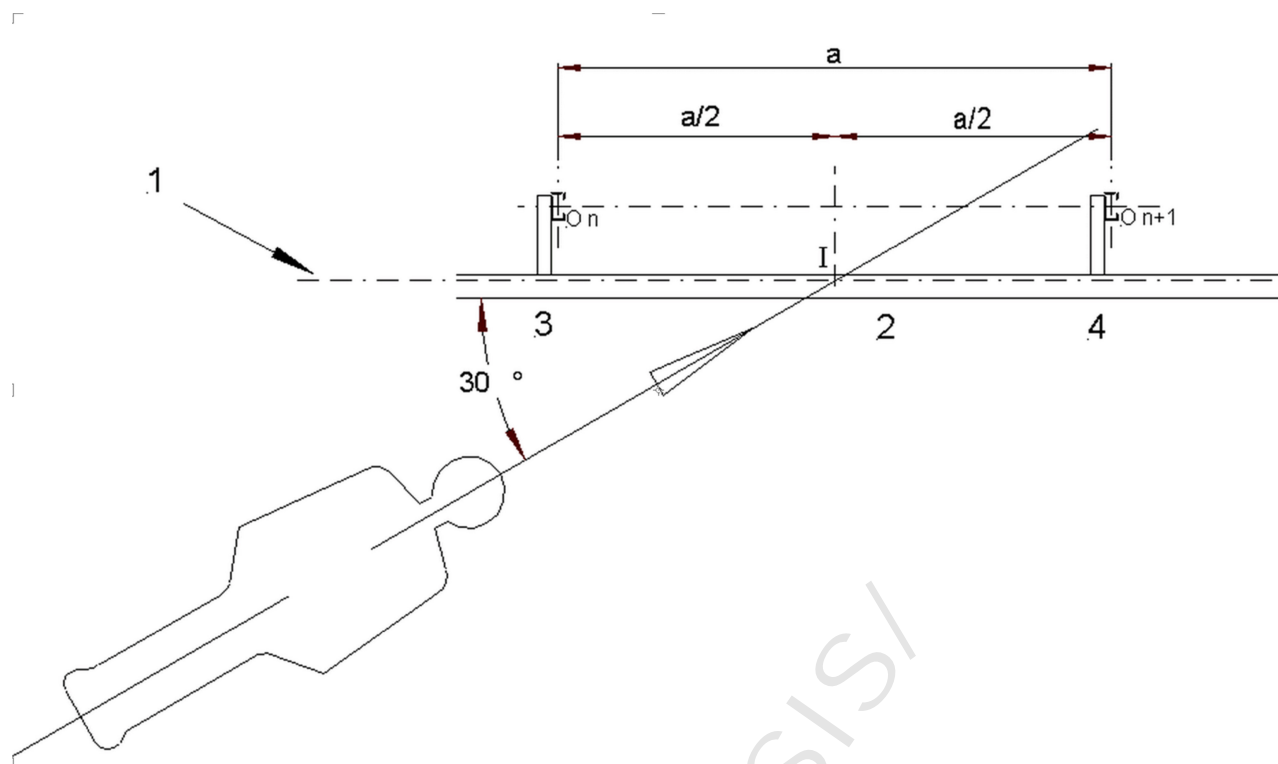

Key

- 1 contact surface of system
- 2 continuous system
- 3 post n
- 4 post n+1

Figure 4 — Launch configuration 3: mid-span impact

When a complete system comprising CMPS and barrier, or an integrated MPS, is longitudinally homogeneous, regarding its material, geometry and structure (i.e. it has no potentially aggressive points such as posts), it shall be sufficient to carry out one ATD impact test, at the centre of the length of the test item with the ATD at an angle of 30° to the test item.

6.10 Accuracies and deviation of impact speeds and angles

6.10.1 ATD impact speed

Two nominal impact speeds are defined: 60,0 km/h and 70,0 km/h

ATD impact speed shall be measured along the ATD approach path with the ATD back and legs stably in contact with the ground and no further than 0,5 m from the theoretical impact point. The overall accuracy of speed measurement shall be within $\pm 1\%$.

The impact speed limit deviation shall be:

- + 6 %;
- 0 %.

6.10.2 ATD approach angle

The approach angle shall be measured at not more than 0,5 m from the theoretical impact point.

SIS-CEN/TS 17342:2019 (E)

The overall accuracy of approach angle measurement shall be within $\pm 0,5^\circ$.

The approach angle limit deviation shall be $\pm 2^\circ$.

6.10.3 ATD orientation

The ATD shall be oriented so that its mid-sagittal plane is aligned with the 30° approach path (see Figure 2, Figure 3 and Figure 4) with a tolerance of $\pm 2^\circ$. This angle requirement can only be an approximation because there is no accessible fixed reference on the ATD to determine this angle (the ATD is mostly covered by clothing which can move relative to the ATD and the ATD flesh can move with respect to the ATD structural parts). However, the orientation requirement shall be observed in as far as is possible.

It is recommended that the ATD mid-sagittal plane be approximately indicated by affixing self-adhesive reference markers to the thorax and pelvis areas of the ATD.

6.10.4 ATD impact point

The lateral displacement of the actual ATD impact point, with respect to the theoretical impact point, shall be measured with an accuracy of ± 15 mm by a suitable method. The permitted deviation of the actual impact point measured longitudinally along the test item is ± 60 mm (see Figure 5).

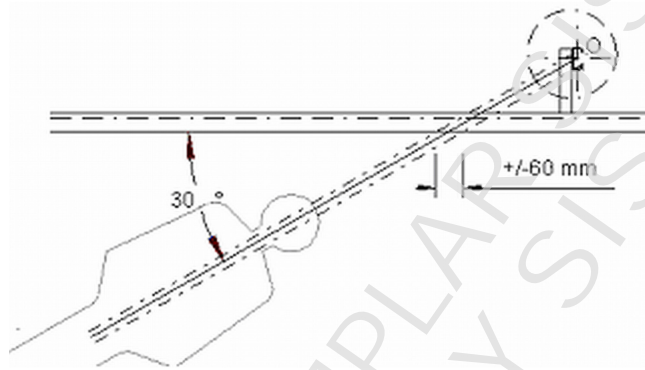

Figure 5 — Impact point position tolerance

6.11 Photographic coverage

Photographic coverage shall be sufficient to describe clearly the MPS, barrier and ATD behaviours during and after the impact.

High-speed cameras shall be operated at a minimum of 200 frames per second.

Normal-speed cameras shall be operated at a minimum of 24 frames per second.

The minimum camera layout below, as shown in Figure 6, shall be adopted:

- one high-speed camera positioned behind the test item, filming the deflection of the test item and the penetration of the ATD into the system. This camera shall be positioned in order to achieve the most informative view of the system and ATD behaviour, but shall generally be positioned obliquely and upstream of the impact point. If the presence of the barrier precludes any of the deflection from being visible from this camera position, then the laboratory shall consider any other possible camera positions that permit suitable alternative views. If no other meaningful views can be identified then camera 4) shall be used;
- one overhead high-speed camera located in such a way as to cover the ATD motion from at least 2 m along the approach path before the impact point until the ATD is no longer in contact with the test item following the test;

- c) one high-speed camera filming along the length of the test item, positioned downstream of the impact point;
- d) one high-speed camera filming along the length of the test item, positioned upstream of the impact point (optional);
- e) one panned camera at normal speed giving a general view showing the whole test (optional).

The need for additional cameras should be considered to cover areas of special interest.

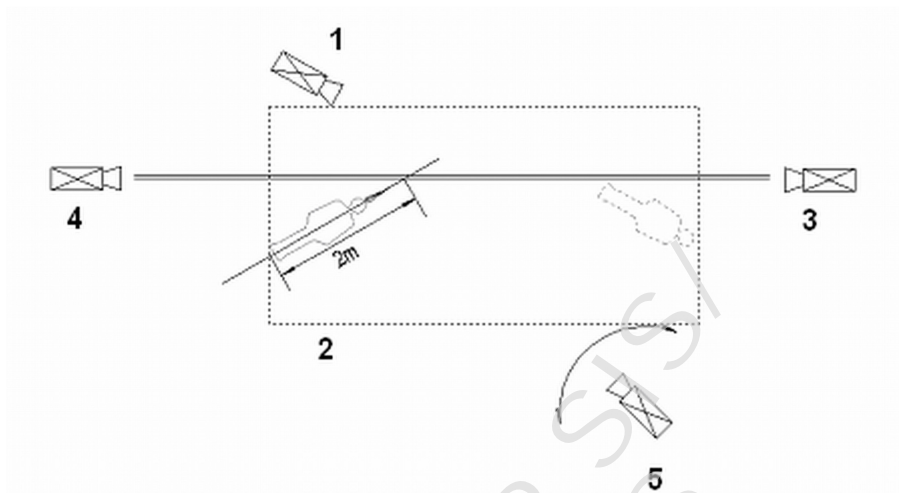

Key

- 1 rear oblique coverage
- 2 overhead coverage
- 3 downstream coverage
- 4 upstream coverage (optional)
- 5 panned (optional)

Figure 6 — Camera coverage

7 Performance classes

7.1 General

MPSs shall conform to the requirements of 7.2, 7.3, 7.4 and Clause 8 when tested in accordance with the relevant impact tests selected from Table 1 with respect to the type of MPS (CMPS or DMPS) and the speed class required.

The performance of an MPS is determined by two performance classes:

- the speed class, which is determined by the impact speed of the tests performed;
- the severity level, which is determined by the level of the biomechanical indices determined from data obtained from the ATD instrumentation during the test.

A tested MPS which satisfies the requirements of a given speed class shall be deemed to comply with the test conditions corresponding to the speed classes of lower speeds, with the same severity levels, unless it contains some mechanism that does not work acceptably at a lower impact speed.

SIS-CEN/TS 17342:2019 (E)

Table 1 — Tests

Test	MPS type	Launch configuration (see 6.9)	Speed
			km/h
TM.1.60	CMPS and DMPS	Post-Centred (1)	60
TM.2.60	DMPS	Post offset (2)	60
TM.3.60	CMPS	Mid-span (3)	60
TM.1.70	CMPS and DMPS	Post-Centred (1)	70
TM.2.70	DMPS	Post offset (2)	70
TM.3.70	CMPS	Mid-span (3)	70

NOTE These tests only evaluate the reduction of impact severity for PTW riders; the vehicle restraint capability of the complete system is assessed as described in 8.4.

7.2 Speed classes

The speed classes for MPSs are defined by the impact speed and are described in Table 2 and Table 3 for DMPSs and CMPSs respectively.

Table 2 — Speed classes for DMPS

Class	Tests required	
	D60	TM.1.60
D70	TM.1.70	TM.2.70

Table 3 — Speed classes for CMPS

Class	Tests required	
	C60	TM.1.60
C70	TM.1.70	TM.3.70

An MPS tested according to the requirements of this document shall be identical for each of the tests performed for a given speed class.

7.3 Severity levels

The severity level of an MPS is determined by the maximum values of the biomechanical indices given in Table 4. For each impact test, two severity levels are defined (level I and level II), according to the maximum values indicated in Table 4.

The severity level is achieved only when the values of all the biomechanical indices in Table 4 are equal to or less than the corresponding maximum limits. Thus, for example, in order to comply with severity

level I, all of the biomechanical indices of an MPS shall be less than or equal to the maximum levels corresponding to level I defined in Table 4.

The severity level that shall be applied to an MPS, for a given speed class, is the highest of the severity levels obtained from the impact tests performed, according to Table 2 or Table 3. (i.e. if severity level I is achieved for one test and severity level II achieved for the other, the MPS shall be classed as severity level II).

If an MPS has been successfully tested for a given speed class and with a certain severity level, it shall be deemed to comply with lower speed classes with the same severity level, unless it has been successfully tested according to this document for a lower speed class and with a lower severity level. In the latter case, the MPS will have a certain severity level for the higher speed class, and another – lower – severity level for the lower speed class.

All severity indices shall be rounded to the nearest whole number using standard mathematical rounding.

The filtering frequency applied to the raw data and those used in graphical representations shall be stated.

Table 4 — Severity levels





Severity level	Maximum admissible values						
	Head	Neck					
		F_x N	F_z tension N	F_z compression N	MOC_x Nm	MOC_y extension Nm	MOC_y flex Nm
HIC_{36}							
I	650	Figure 7	Figure 8	Figure 9	134	42	190
II	1 000	Figure 10	Figure 11	Figure 12	134	57	190

Figure 7 to Figure 12 show graphs giving maximum permissible load durations for given neck load levels (as referred to by Table 4).

SIS-CEN/TS 17342:2019 (E)

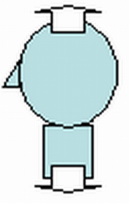

Key

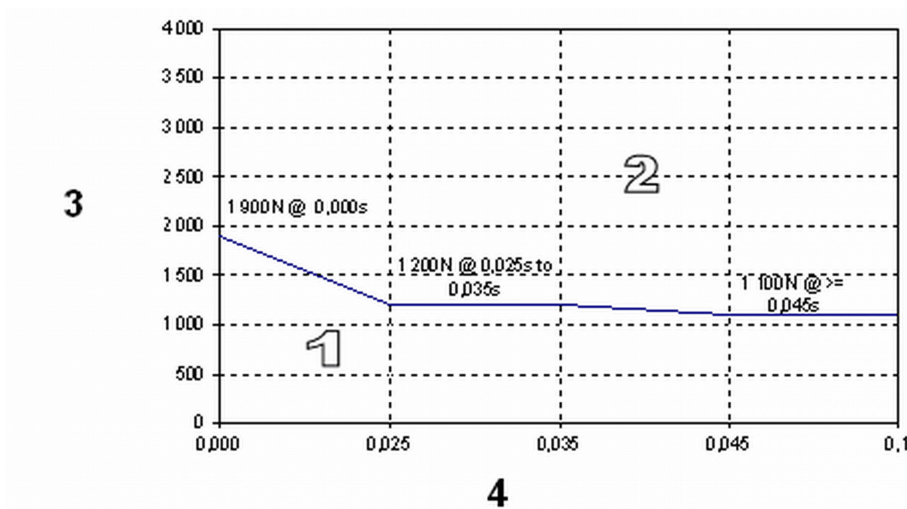
- 1 PASS
- 2 FAIL
- 3 Anterior-posterior neck shear force (N)
- 4 Permitted duration for a given shear force (s)

Figure 7 — Anterior-posterior neck shear force criterion for level I

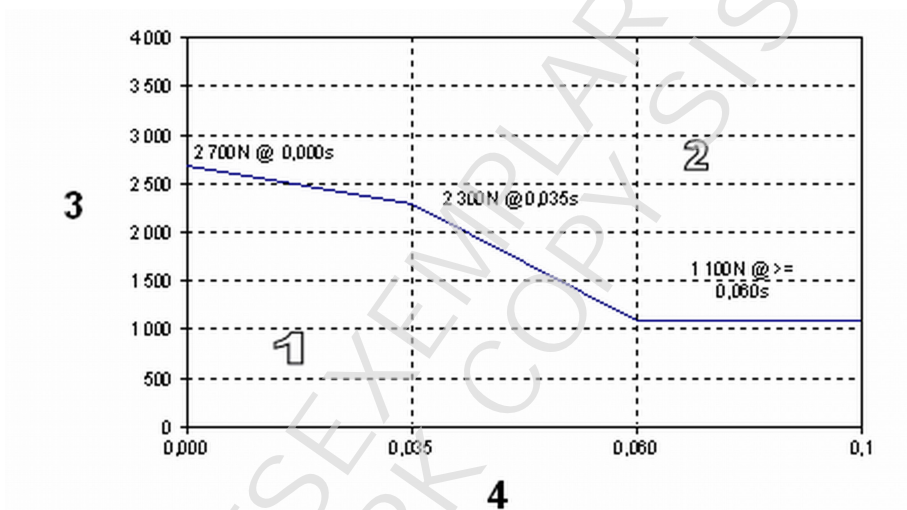

Key

- 1 PASS
- 2 FAIL
- 3 Axial neck tension (N)
- 4 Permitted duration for a given axial neck tension (s)

Figure 8 — Axial neck tension criterion for level I

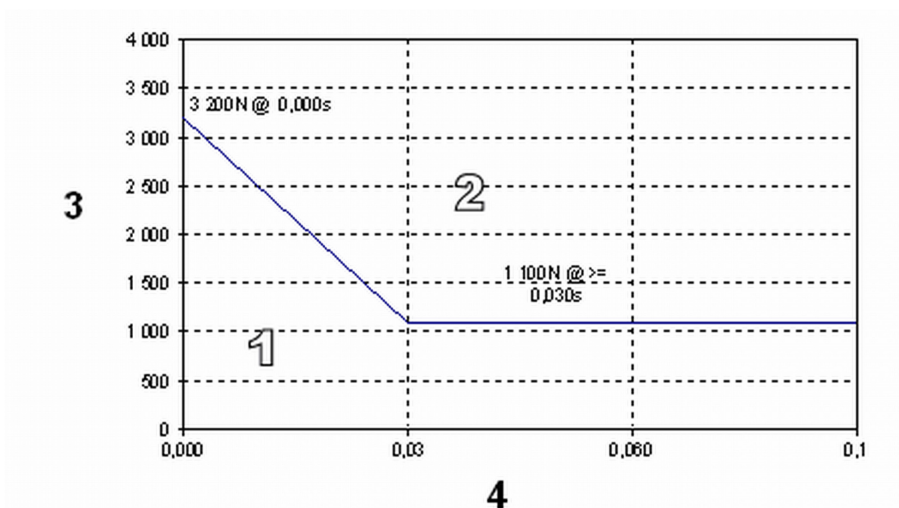

Key

- 1 PASS
- 2 FAIL
- 3 Axial neck compression (N)
- 4 Permitted duration for a given axial compression (s)

Figure 9 — Axial neck compression criterion for level I

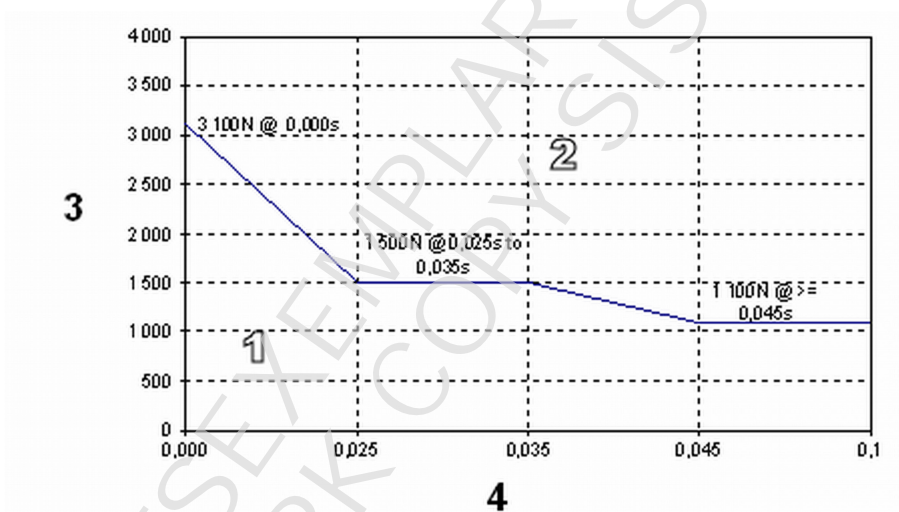

Key

- 1 PASS
- 2 FAIL
- 3 anterior-posterior neck shear force (N)
- 4 permitted duration for a given shear force (s)

Figure 10 — Anterior — Posterior neck shear force criterion neck for level II

SIS-CEN/TS 17342:2019 (E)

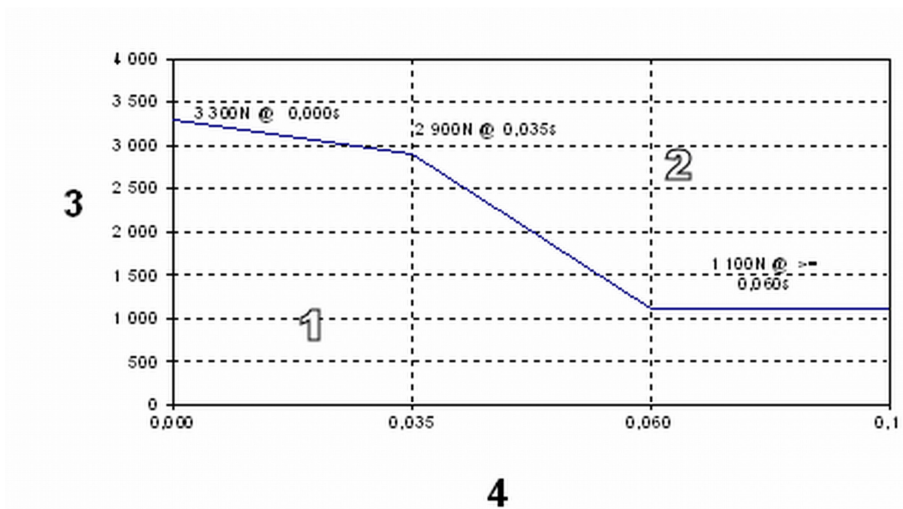

Key

- 1 PASS
- 2 FAIL
- 3 Axial neck tension (N)
- 4 Permitted duration for a given axial tension (s)

Figure 11 — Axial neck tension criterion for level II

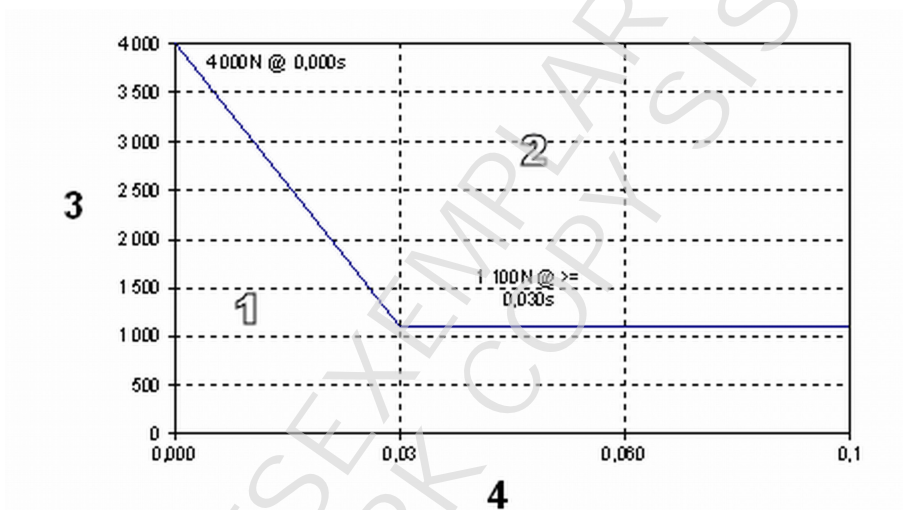

Key

- 1 PASS
- 2 FAIL
- 3 Axial neck compression (N)
- 4 Permitted duration for a given axial compression (s)

Figure 12 — Axial neck compression criterion for level II

7.4 Deformation of the CMPS

For CMPS only (including integrated MPS) the dynamic deformation of the test item during the test with an ATD is characterized by the working width: W_d . The W_d is the distance between the foremost part of the undeformed system and the maximum dynamic lateral position of any part of the system (see Figure 13). If the hand of the ATD protrudes past the rearmost part of the system during the test then the position of this ATD part shall be taken into account in the determination of W_d . Protrusion of any other ATD part shall constitute a failure of the test as stated in 8.2.

8 Acceptance criteria of the impact test

8.1 MPS behaviour

There shall be no complete rupture of any longitudinal element of the test item.

If W_d (see Figure 13) exceeds the working width of the complete test item, the barrier alone or the integrated MPS tested according to EN 1317-2 then the working width of the complete system shall be equal to W_d .

8.2 ATD behaviour

Following the test, the ATD shall not remain trapped in the test item. The ATD shall be deemed to be trapped when in contact with the test item in such a way as to require further deformation or displacement of the test item, or dismantling of the ATD, in order to remove the ATD from the test item.

No limb, or part of a limb, nor the head or neck of the ATD shall become totally detached from the ATD following impact with the test item except for detachment of the upper extremity due to rupture of the frangible screws in the shoulder assembly of the ATD.

There shall be no lacerations to the ATD flesh resulting from the test.

NOTE The ATD flesh is not designed to have humanlike resistance to this form of damage. Therefore, it is not possible to evaluate the severity of any injuries that would be suffered by a human rider on the basis of the seriousness of any lacerations to the ATD flesh. However, if lacerations to the ATD flesh occur during the test then it can be concluded that the protective clothing has been sufficiently penetrated to expose the flesh of a rider to a significant risk of serious laceration. Thus, laceration is considered to be an unacceptable result.

For CMPS only, during the test, no ATD body parts, with the exception of the hand, shall protrude rearwards of the elements in contact with the ATD. Protrusion of the hand only is acceptable provided that the ATD is not trapped by the test item after the test. No other ATD part shall protrude rearwards of the elements in contact with the ATD even if they subsequently return in front of the test item.

SIS-CEN/TS 17342:2019 (E)

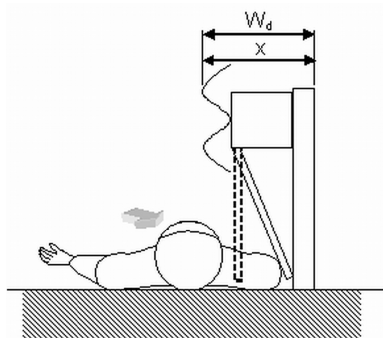

a) Example: barrier + MPS
No protrusions rearward of complete system
→ ACCEPTABLE PERFORMANCE

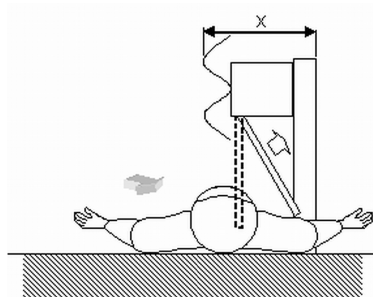

b) Example: barrier + MPS
Arm protrudes rearward of complete system
→ SYSTEM FAILS TEST

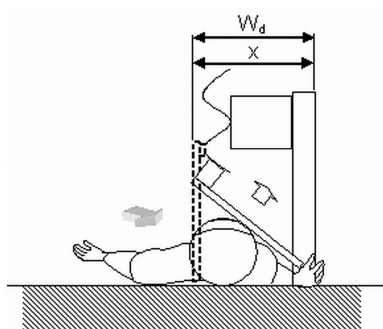

c) Example: barrier + MPS
Hand protrudes rearward of complete system but is not trapped in system after test
→ ACCEPTABLE PERFORMANCE
 W_d determined by rearmost part of system

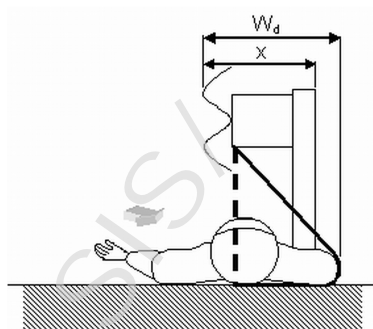

d) Example: barrier + flexible MPS
ATD contained by MPS and MPS protrudes behind barrier
→ ACCEPTABLE PERFORMANCE
 W_d determined by rearmost part deformed MPS

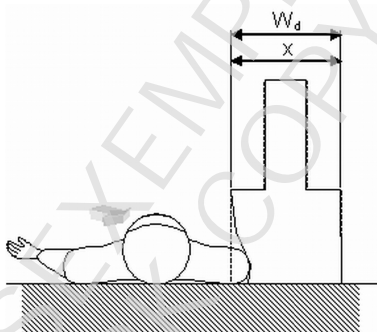

e) Integrated MPS or MPS on modular or wall-type barrier
No protrusions rearward of complete system
→ ACCEPTABLE PERFORMANCE
 W_d determined by rearmost part of system

Key

x initial width of un-deformed system (MPS + barrier or integrated MPS)

W_d dummy test working width

Dotted lines show un-deformed MPS.

Figure 13 — Determination of W_d

8.3 Severity indices

The maximum values of the biomechanical indices shall in no case exceed the values indicated in Table 4 for severity level II.

8.4 Vehicle impact performance

Any barrier with an MPS added to it, or any integrated system shall also conform to the requirements of EN 1317-2 for the appropriate containment level.

EXAMPLE 1 An H3 barrier, already meeting the requirements of EN 1317-2, fitted with an add-on MPS, will also have to meet the requirements of EN 1317-2 with MPS fitted (TB11 and TB61) in addition to meeting the requirements of this document.

EXAMPLE 2 An N₂ level VRS with integrated MPS function will also have to meet the requirements of EN 1317-2 (TB11 and TB32) in addition to meeting the requirements of this document.

9 Test report

The test report shall comply with Annex A.

ARBETSEXEMPLAR SIS/
WORK COPY SIS/

Annex A **(informative)**

Detailed report template

In addition to the video records in accordance with 6.11, the test report should include the following information as a minimum, in the order given. All drawings and associated documents should be clearly numbered and dated.

Test report covers:

- Name of test laboratory
- Date of report
- Name of client
- Name of test item
- Name of barrier (in the case of an MPS fitted to a barrier)
- Date of test
- Test number and/or test report number (version number if applicable)
- Test type and reference to document
- Number of pages including annexes
- Official test report language
- Approval of report

Table of contents

1. Test laboratory
 - 1.1 Name
 - 1.2 Address
 - 1.3 Telephone number
 - 1.4 Facsimile number
 - 1.5 Internet address
 - 1.6 Test site location
 - 1.7 Name and address of body which accredited the test laboratory
 - 1.8 Notification/accreditation number with date of approval, valid at the time of testing
 - 1.9 Additional information
2. Client
 - 2.1 Name

2.2 Address

2.3 Telephone number

2.4 Facsimile number

2.5 Internet address

2.6 Additional information

3 Test item

3.1 Name of MPS

3.2 Name of barrier used in test

3.3 Date(s) of installation (Include, where relevant, dates for the total completion of installation of MPS and barrier.)

3.4 Date of test

3.5 Laboratory's test reference number

3.6 Additional information

4 Test procedure

4.1 Test type (according to Table 1)

4.1.1 Type of impact test (for example, TM.1.60)

4.1.2 Nominal impact speed

4.1.3 Nominal impact angle

4.1.4 Additional information

4.2 Test area

4.2.1 Description of type and condition of test area

4.2.2 Schematic plan of ATD approach including angle, impact point and test item (including position of nominal impact point with respect to a reference point on the test item)

4.2.3 Justification of impact point choice

4.2.4 Where the tested system includes a vehicle parapet, the distance between the contact surface of the MPS and the bridge deck edge

4.2.5 Type of underground (soil or foundation type into which the system is installed)

4.2.6 Class/condition of underground

4.2.7 Additional information

4.3 Installation and detailed description of test item

4.3.1 Conformity between test item drawings and item tested (giving details of those characteristics that have been checked and methods used [e.g. checking by tape measure, calliper] noting any non-conformities identified)

Conformity between test item drawings and the item tested shall be checked by the test laboratory with respect to the assembly of the test item and to overall component dimensions. However, more detailed analysis may be required following the test in order to meet the requirements for the evaluation report of the test item.

4.3.2 Conformity between installation manual and item installation (giving details of those characteristics that have been checked and methods used, noting any non-conformities identified)

SIS-CEN/TS 17342:2019 (E)

- 4.3.3 Description of the MPS tested which shall include the following.
 - 4.3.3.1 General description of the MPS and of the barrier onto which it fixed for the test
 - 4.3.3.2 Details of fixing the MPS to the barrier and/or to the ground
 - 4.3.3.3 Total length of test item in metres
 - 4.3.3.4 Height of lower edge of restraining part of system with respect to the ground (as a minimum at the nominal impact point and at 1 m intervals throughout the expected impact zone with a minimum of 8 m)
 - 4.3.3.5 Support spacing and/or unit length (in metres)
 - 4.3.3.6 Value(s) of the applied tension(s) where the MPS and/or the barrier is pre-tensioned
 - 4.3.3.7 Any additional information to describe the tested system sufficiently (e.g. fastening torques)
- 4.4 Description of ATD and equipment
 - 4.4.1 Type of ATD used (refer to 6.4 of this document)
 - 4.4.2 Helmet type (brand, model, size, date of purchase)
 - 4.4.3 Description of ATD clothing
 - 4.4.4 ATD mass (without clothing and helmet)
 - 4.4.5 Helmet mass
 - 4.4.6 Clothing mass (suit, gloves and boots)
 - 4.4.7 Total ATD mass including helmet and clothing
- 5 Results
 - 5.1 Test conditions
 - 5.1.1 Actual impact speed in kilometres per hour
 - 5.1.2 % difference from nominal speed
 - 5.1.3 Actual impact angle in degrees
 - 5.1.4 Difference from nominal angle in degrees
 - 5.1.5 ATD orientation angle within tolerance? (Yes/No)
 - 5.1.6 Distance of actual impact point from nominal impact point
 - 5.1.7 Impact point position within tolerance? (Yes/No)
 - 5.1.8 Ambient temperature
 - 5.1.9 Relative humidity
 - 5.1.10 General description of test sequence
 - 5.1.11 Any additional information
 - 5.2 Test item behaviour
 - 5.2.1 Complete rupture of any principal longitudinal elements of the test item? (Yes/No) – if yes, description is required.
 - 5.2.2 Working width (Wd) in metres
 - 5.2.3 Length in metres of ATD contact with tested system from initial impact point to the point of contact furthest downstream from the initial impact point

- 5.2.4 Description of damage to the tested system (including to barrier where appropriate) e.g. permanent deformation, relative displacement of elements
- 5.2.5 ATD trapped in test item following test? (Yes/No) – if yes, give details
- 5.2.6 Parts of ATD protruding rearwards of contact elements of test item during test? (Yes/No) – if yes give details
- 5.2.7 Parts of ATD protruding rearwards of contact elements of test item after test? (Yes/No) – if yes give details
- 5.2.8 Elements of ATD detached during test (other than detachment of upper extremities due to rupture of frangible shoulder screws)? (Yes/No) – if yes give details
- 5.2.9 Lacerations to flesh of ATD? (Yes/No) – if yes give details (including details of damage to clothing)
- 5.2.10 General description of ATD trajectory
- 5.2.11 ATD final resting position (indicate whether ATD brought to rest by a restraining system – if so, indicate that ATD was brought to rest after the end of the test event).
- 5.2.12 Graphical representations of x, y, z and resultant head accelerations
- 5.2.13 Head injury criterion
- 5.2.14 Graphical representations of neck loads and neck moments (levels and durations)
- 5.2.15 Summary of head and neck severity levels:
- all severity indices shall be rounded to the nearest whole number using standard mathematical rounding;
 - the filtering frequency applied to the raw data and those used in graphical representations shall be stated.
- 6 General statements
- 6.1 The test results in this report relate only to the MPS and the corresponding supporting system (e.g. barrier) tested.
- 6.2 This report may not be reproduced other than in full, except with the prior written approval of the issuing laboratory.
- 7 Approval of report
- 7.1 Signature(s)
- 7.2 Name(s) of authorized and responsible person(s) of test laboratory
- 7.3 Position(s)
- 7.4 Date
- 8 Annexes
- A General test item arrangement drawings (overview drawing) of the complete item tested and all component drawings, including drawing number and date of issue, dimensions, tolerances and materials. All drawings to be authorized by the client, by signing the drawings.
 - B MPS and supporting barrier installation manual including dimensions and tolerances
 - C Dimensioned plan of test installation
 - D Ground conditions

SIS-CEN/TS 17342:2019 (E)

- E Helmet calibration curve
- F Photographs
 - F.1 Photographs of the complete system to be tested before the test
 - F.2 Photographs of ATD, clothing and helmet before test
 - F.3 Sequences and additional photographs of the test event (stating frame rate for films)
 - F.4 Photographs of the complete system after the test (including damage to the system)
 - F.5 Photographs of the ATD after the test in its final rest position
- G Video records (give frame rate)

ARBETSEXEMPLAR SIS/
WORK COPY SIS/

Annex B (informative)

Anthropomorphic test device

The ATD used in this document (excluding the modifications below) shall be a Hybrid III 50th percentile male ATD³.

The ATD neck regulating system (neck bracket) shall be adjusted to a nominal angle of - 7°.

The Hybrid III ATD used in this document shall incorporate the following modifications:

- substitution of the original pelvis and lumbar spine by the pelvis reference 78051-60P and the lumbar spine reference 78051-66P and their accessories to allow the ATD to adopt an upright position;
- substitution of both of the original shoulder assemblies by the modified shoulder described in Annex D;
- installation of a foam neck shield, reference 1039006, on the neck to ensure correct adjustment of the chin strap buckle.

For the purposes of this document, certification tests⁴ shall have been successfully performed for at least the head and neck. These certification tests shall be successfully performed after the corresponding ATD parts have been used in no more than ten impact tests, or if one of the injury criterion limits described in Clause 7 of this document has been exceeded.

In accordance with 49 CFR Part 572 Subpart E, 572.36 (I), Limb joints are set at 1G, barely restraining the weight of the limb when it is extended horizontally. The force required to move a limb segment shall not exceed 2G throughout the range of limb motion.

The air temperature of the area used for long-term storage of the ATD shall be between 13 °C and 30 °C. Beginning at least 3 h before the planned time of impact, the air temperature wherever the ATD and helmet are being stored or prepared shall be measured and documented. If the temperature measured remains between 13 °C and 30 °C, then no additional temperature soaking procedures shall be used. If the temperature in any of the ATD preparation or storage areas is outside this range, and the total exposure time to the out of range temperature exceeds the time t given by Formula (B.1) below, where first area is the soak area and the second area is the out of range area, then the ATD and helmet shall be soaked according to the following temperature soaking procedure.

Place the ATD and helmet in an area which has an air temperature in the required range, for a period of time t , where the first area is the out of range area, and the second area is the soak area.

$$t = \tau \times \ln [T_2 - T_1 / T_2 - T_0] \quad (\text{B.1})$$

³ In conformance with US. Department of transportation Code of Federal Regulations Title 49, Part 572, Subpart E [13].

⁴ These tests are defined in the US. Department of transportation Code of Federal Regulations Title 49, Part 572, Subpart E [13] (frontal impact requirements including both flexion and extension for the neck) and in Title 49, Part 572, Subpart M [14] (side impact requirements).

SIS-CEN/TS 17342:2019 (E)

where

- t is the total exposure time required to reach the limit of the temperature range, in hours;
- T_1 is the air temperature in the first area, in degrees Celsius;
- T_2 is the air temperature in the second area, in degrees Celsius;
- T_0 is the critical temperature, in degrees Celsius: 13 °C for moving to or from temperatures colder than the required range; 30 °C for moving to or from temperatures warmer than the required range;
- τ is 2,9, the ATD thorax thermal time constant, in hours.

ARBETSEXEMPLAR SIS/
WORK COPY SIS/

Annex C (informative)

Helmet alignment tool

Prior to the test, the helmet shall be located on the ATD head using the helmet alignment tool described in Figure C.1. This profiled template fits closely over the nose of the Hybrid III 50th Percentile Male and thus indicates the angle of the instrumentation plane of the ATD head (see Figure C.2).

In order to achieve the correct position of the helmet relative to the head, the helmet is fitted on the head. The helmet is positioned so that the vertical centreline of the visor aperture is aligned with the centreline of the face. The helmet is then rotated relative to the head in the mid-sagittal plane so that the alignment tool can be passed through the visor aperture and fits snugly onto the face. With the tool positioned in this way, the upper edge of the visor aperture is in contact with the upper edge of the tool. The 16 mm deep cut-out is provided in case the visor cannot be raised above the top edge of the tool.

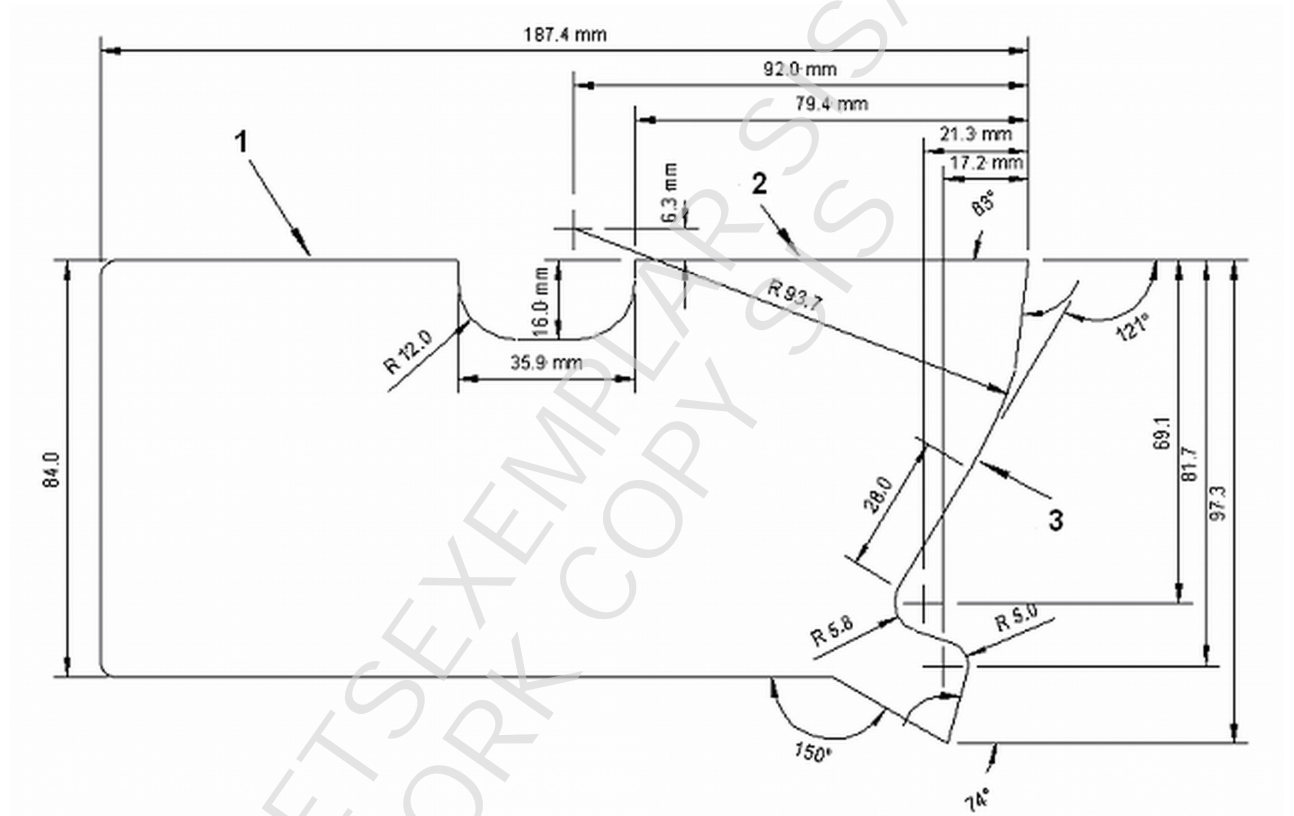

Key

- 1 Edge parallel to instrumentation plane of ATD head
- 2 Edge in contact with upper edge of helmet visor aperture
- 3 Fit over ATD nose

Figure C.1 — Pattern for helmet alignment tool

SIS-CEN/TS 17342:2019 (E)



Material: 3 mm aluminium sheet

The linear dimensions are in mm and have a $\pm 0,03$ mm tolerance

The angular dimensions have a $\pm 1^\circ$ tolerance

All the radii are 3,2 mm unless otherwise specified. Sharp edges shall be removed

Figure C.2 — Use of helmet alignment tool

Annex D (informative)

Modification of the anthropomorphic test device shoulder

Both standard shoulders of the Hybrid III ATD shall be replaced by a specific shoulder design with two parts of the shoulder assembly fixed together with frangible screws, as described in the drawings included in this Annex. This modification provides for the repeatable collapse of the shoulder during testing whereas the standard Hybrid III shoulder will exhibit unrepeatable modes of failure under the loading conditions applied in these tests, which could influence the test results.

The reference of the part to be substituted is 78051-141 for the left shoulder or 78051-142 for the right.

The frangible screws used are two M4 × 35 mm screws as described by EN ISO 4762, with a maximum breaking load when statically tested of 7,600 N ± 5 % and a minimum displacement between clamps of 2 mm.

The test laboratory shall ensure, using suitable means, that the screws used in the tests fulfil the previously described requirements. The use of periodical static traction tests on samples of each batch of screws to be used in the tests is recommended.

The shoulder assembly, as shown in Figure D.1 to Figure D.5, shall be installed on both sides of the ATD with class 8.8 bolts and double nuts and tightened to a torque of 2,7 N m.

ARBETSEXEMPLAR
WORK COPY SIS

SIS-CEN/TS 17342:2019 (E)

Dimensions in millimetres

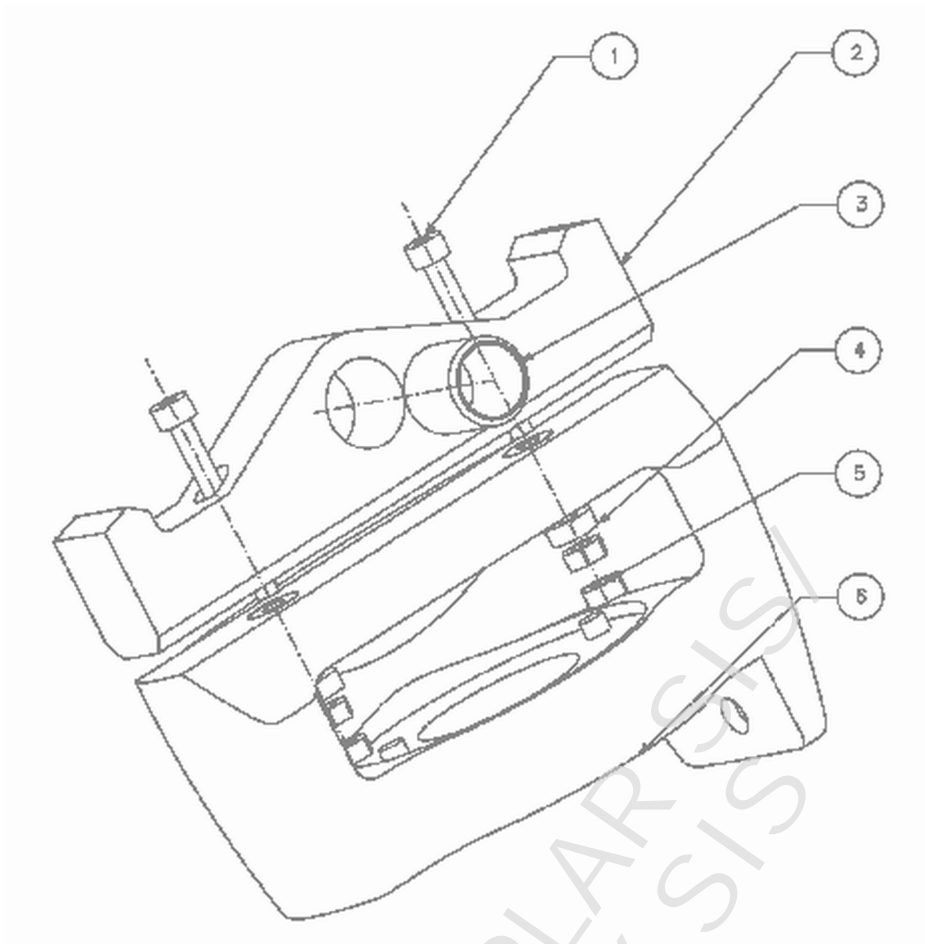

6	PART B		1	1	ALUMINIUM	
5	NUT	M4 - DIN 934 - 8		4		
4	WASHER		2	2	F 1140	
3	BUSH		3	1	PVC	
2	PART A		4	1	AA5083	
1	SCREW	M4 X 35 - DIN 912 - 8.8		2		
Brand	Denomination	Commercial Ref.	Drawing No.	No. of Parts	Material	Dimensions
Revisions		Treatment:		Denomination		
	Author	General Tol.	Scale	ASSEMBLY		
		UNE 22768-mK	1:1			
	Date	UNE 1037	Date	Name		
		Drawn by				
		Approved by				
	No.	UNE 22553	(If the opposite is not indicated in welded unions)	UNE 1037		
R1		$\frac{z}{2}$	z = plate thickness	$\frac{z}{2}$	$\frac{z}{2}$	

Figure D.1 — Exploded view of frangible left shoulder assembly

SIS-CEN/TS 17342:2019 (E)

Dimensions in millimetres

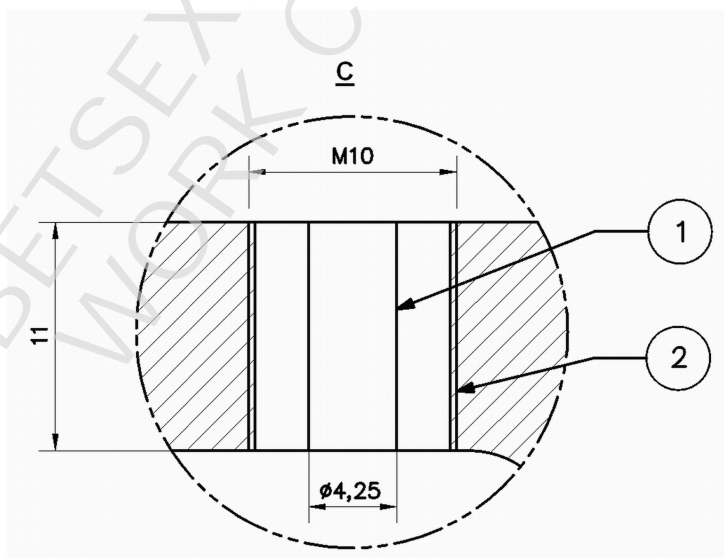
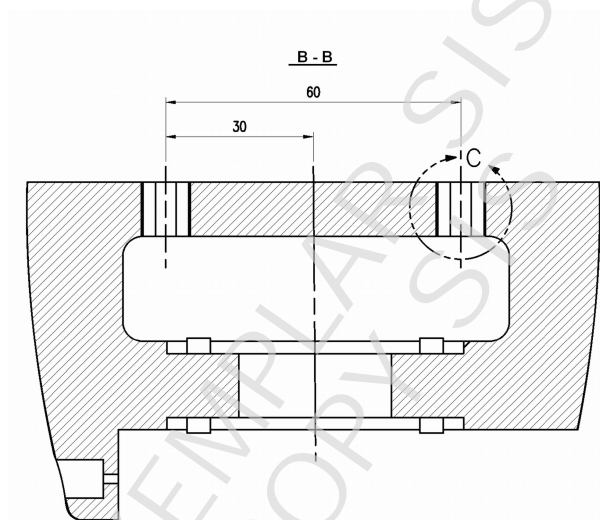
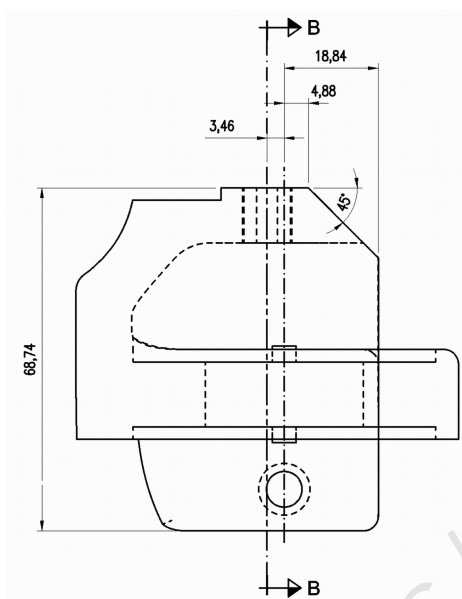

SIS-CEN/TS 17342:2019 (E)

2	PART_B		1	1	ALUMINIUM	
1	BOLT	CYLINDRIC BOLT M10 X 15 DIN 912 – 8.8		2		
Brand	Denomination	Commercial Ref.	Drawing N°	N°Of Parts	Material	Dimensions
Revisions		Treatment:		Denomination		
	Author	General Tol. UNE 22768–mK	Scale 1:1	PART B		
	Date	UNE 1032 	Date	Name		
		Drawn by				
		Approved by				
		UNE 22553 <small>(If the opposite is not indicated in welded unione)</small>	UNE 1037			
	R1	 z = $\frac{\text{plate thickness}}{2}$	 = $\frac{N9}{\sqrt{\quad}}$			

Figure D.2 — Drawing of the original left side shoulder component and the modification to it

ARBETSEXEMPLAR SIS/TK 248
WORK COPY SIS/TK 248

Dimensions in millimetres

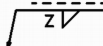
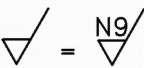
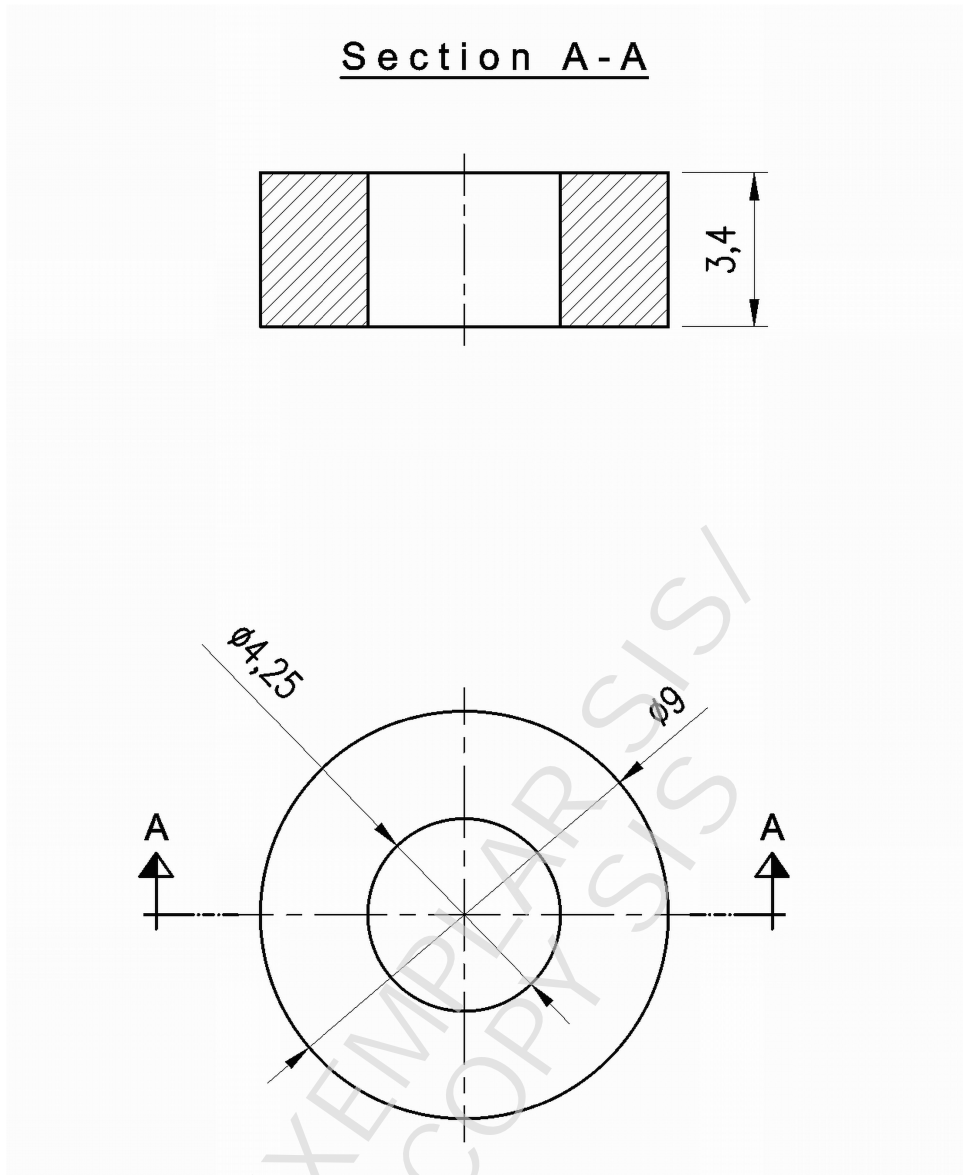

	WASHER				2	F 1140	ø9 x 5
Brand	Denomination		Commercial Ref.	Drawing N°	N°Of Parts	Material	Dimensions
Revisions		Treatment:		Denomination			
		General Tol.	Scale	PART B			
	Author	UNE 22768-mK	5:1				
	Date	UNE 1032	Date	Name			
		Drawn by					
		Approved by					
		UNE 22553	(If the opposite is not indicated in welded unions)	UNE 1037			
		\sqrt{z}	z = $\frac{\text{plate thickness}}{2}$	$\sqrt{\quad} = \sqrt{N9}$			

Figure D.3 — Drawing of the washer for the frangible shoulder

SIS-CEN/TS 17342:2019 (E)

Dimensions in millimetres

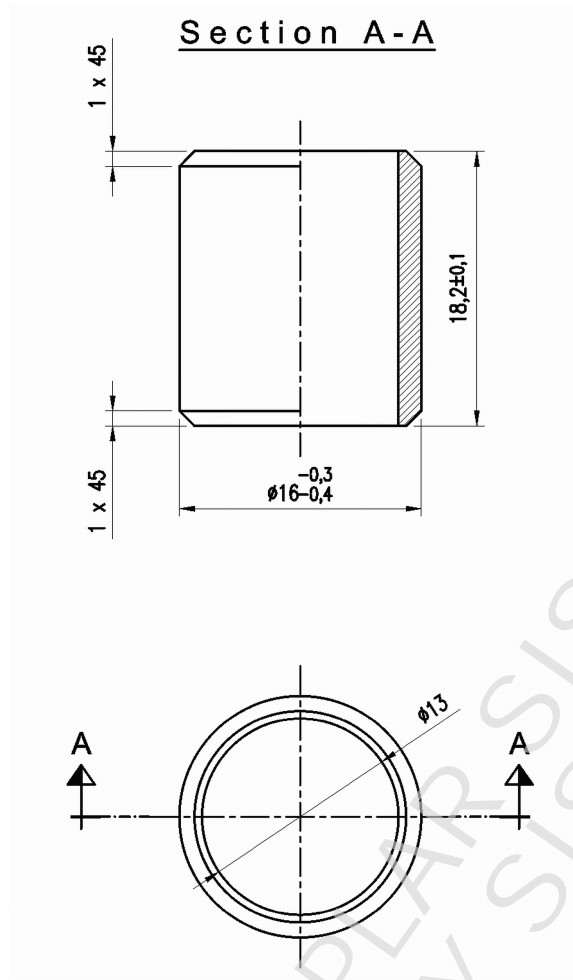

	BUSH			3		PVC	Ø16 x 18.5
Brand	Denomination		Commercial Ref.	Drawing N°	N°Of Parts	Material	Dimensions
Revisions		Treatment:		Denomination			
		Author	General Tol.	Scale	BUSH		
			UNE 22768-mK	2:1			
		Date	UNE 1032	Date	Name		
			Drawn by				
			Approved by				
			UNE 22553 (if the opposite is not indicated in welded unions)	UNE 1037			
	R1	N°	$\sqrt{\frac{z}{2}}$ z = plate thickness	$\sqrt{\frac{N9}{2}}$			

Figure D.4 — Drawing of the washer for the frangible shoulder

Dimensions in millimetres

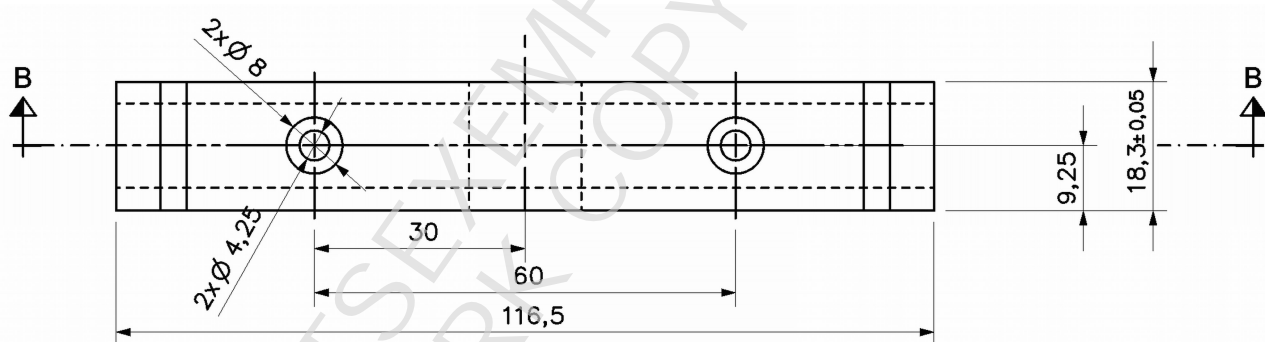
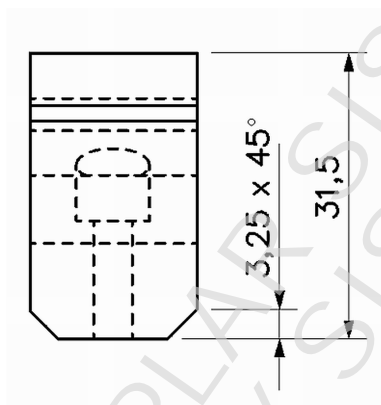
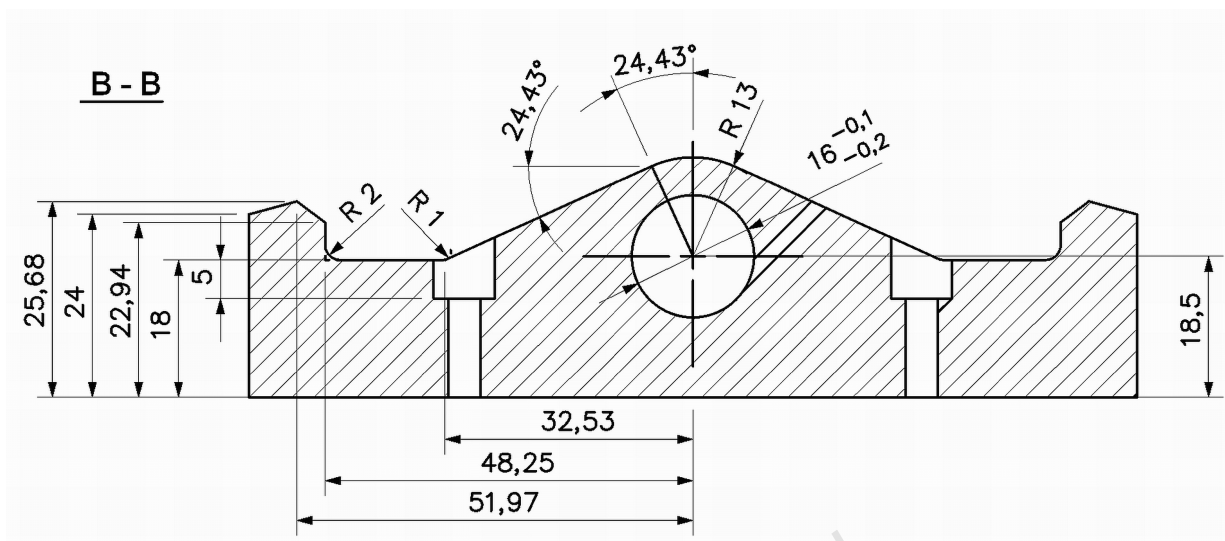

SIS-CEN/TS 17342:2019 (E)



1	PART		4	2	AA5083	116.5 x 31.5 x 18.5
Brand	Denomination	Commercial Ref.	Drawing N°	N°Of Parts	Material	Dimensions
Revisions		Treatment:		Denomination		
		General Tol.	Scale	PART		
		UNE 22768-mK	1:1			
		UNE 1032 	Date	Name		
		Drawn by				
		Approved by				
		UNE 22553 <small>(if the opposite is not indicated in welded unions)</small>	UNE 1037			
		 z = $\frac{\text{plate thickness}}{2}$	 = $\frac{N9}{\nabla}$			
	R1	N				

Figure D.5 — Drawing of the part A joining piece

ARBETSEXEMPLAR SIS/
WORK COPY SIS/

Annex E
(informative)

Reference helmet

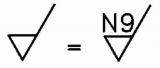
The reference crash helmet is the integral helmet of the NZI brand, model Zoom R, size 57, also available on the market under the HX brand, model Activy. An alternative model is the Eurus 600, size S.

ARBETSEXEMPLAR SIS/
WORK COPY SIS/

Annex F (informative)

Helmet calibration procedure

F.1 General

To ensure that the influential characteristics of the helmet are within a specific range, a calibration procedure shall be conducted. This procedure shall be considered valid only for helmets of same manufacturer, model, type, size and surface finish (matt, glossy, rubber, ...).

F.2 Helmet description

The helmet used for testing shall be an integral type, with polycarbonate shell, round-shaped and free from protruding parts, vents roughness or any kind of unevenness, so that the contact conditions could not be influenced by any such feature.

The helmet shall comply with the requirements set out in the relevant regulation⁵ and shall be new for each test.

F.3 Procedure description and layout

Calibration procedure requires, for a calibration test that shall be repeated three times, using a new helmet identical for each repetition.

The calibration test shall be carried out in a horizontal configuration, as shown in Figure F.1, with a fully guided rigid plate (steel-made with a minimum thickness of 10 mm, and surface finish of 0,2 µm to 2 µm) impacting the helmet fitted on Hybrid III 50th percentile ATD head and neck. Steel plate dimensions shall be enough to ensure appropriate contact with helmet's shell during the test.

The helmet and ATD neck and head shall be assembled and aligned according to Annex B and Annex C, with neck lower bracket firmly attached to a rigid structure. No displacement or deformation in that structure is allowed.

The rigid plate shall be guided during the impact in the vertical plane perpendicular to its approach path and shall be free of external propulsion from before the impact until the end of the calibration test. The approach path shall coincide with the centreline of the neck and head.

Test parameters:

- impactor total mass: 75^{+1}_{-1} kg (total moving mass: plate, guidance device and fixings);
- impact speed: $5,5^{+0,15}_{-0,15}$ m/s;
- impact angle: 30^{+1}_{-1} °.

⁵ See Regulation 22 of ECE/TRANS/505 [22].

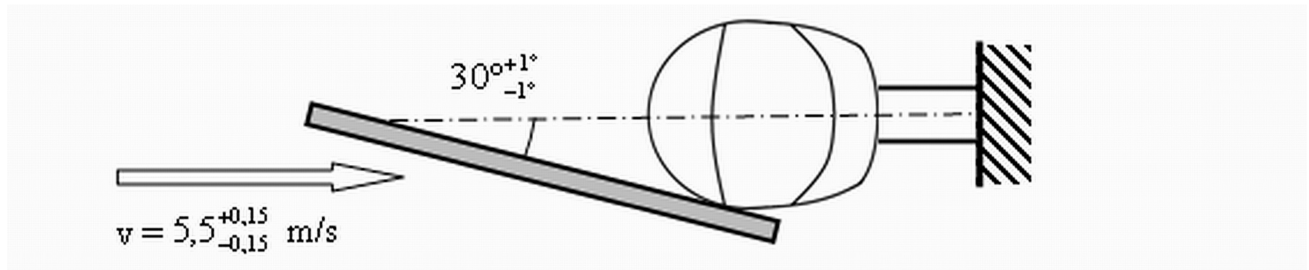

Figure F.1 — Calibration test configuration

The head, neck and helmet shall be conditioned at a temperature of 22^{+2}_{-2} °C for at least two hours before test execution.

The surfaces of the helmet and the rigid plate shall be clean, dry and free of any item or substance (markers, stickers, ...) that may affect the contact between both surfaces.

During the test, F_z and Moc_x shall be acquired and filtered according to 5.3 and 6.4 of this document and to ISO 6487 requirements.

F.4 Helmet assessment

The following requirements shall be fulfilled for each of the three tested helmets.

- The helmet shell shall not become broken; however, detachment of the shield or vent covers is allowed.
- The F_z compression curve during first 22 ms of contact shall lie within the unshaded area of the timeforce curve in Figure F.2. It is permitted to shift the force/time curve in time in order to obtain the best fit.
- The first peak of Moc_x shall lie within 20 N m and 80 N m.

ARBETSEXEMPLAR SIS
WORK COPY

SIS-CEN/TS 17342:2019 (E)

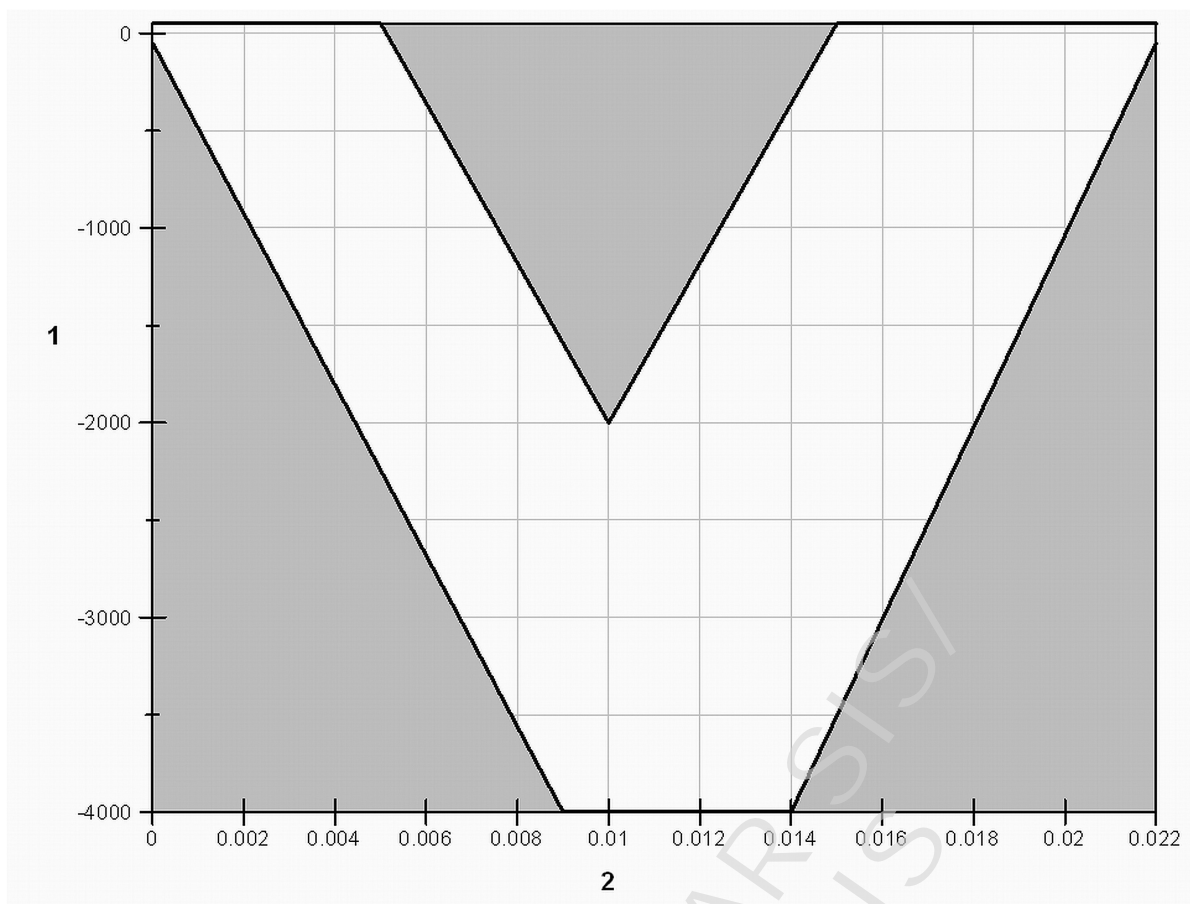

Key

- 1 F_z (N)
- 2 time (s)

Time ms	F_z lower limit N
0	- 50
9	- 4 000
14	- 4 000
22	- 50

Time ms	F_z upper limit N
0	50
5	50
10	- 2 000
15	50
22	50

* Sign convention according to 5.3 of this document.

Figure F.2 — Time F_z force curve

Bibliography

- [1] Regulation (EC) No 661/2009 of the European Parliament and of the Council of 13 July 2009 concerning type-approval requirements for the general safety of motor vehicles, their trailers and systems, components and separate technical units intended therefor (Text with EEA relevance) available from: <https://eur-lex.europa.eu/legal-content/EN/TXT/PDF/?uri=CELEX:32009R0661&from=en>
- [2] E/ECE/TRANS/505 Regulation No. 22, Uniform provisions concerning the approval of protective helmets and of their visors for drivers and passengers of motorcycles and mopeds, United Nations Economic Commission for Europe (UNECE), available from: <http://live.unece.org/fileadmin/DAM/trans/main/wp29/wp29regs/r022r4e.pdf>
- [3] EN 1317-1⁶, *Road restraint systems – Part 1: Terminology and general criteria for test methods*
- [4] EN 1317-3⁷, *Road restraint systems – Part 3: Performance classes, impact test acceptance criteria and test methods for crash cushions*
- [5] EN 1317-5⁸, *Road restraint systems – Part 5: Product requirements and evaluation of conformity for vehicle restraint systems*
- [6] EN 1317-7⁹, *Road restraint systems – Part 7: Performance classes, impact test acceptance criteria and test methods for terminals of safety barriers*
- [7] EN ISO 4762, *Hexagon socket head cap screws (ISO 4762)*
- [8] ISO 13232 (all parts), *Motorcycles – Test and analysis procedures for research evaluation of rider crash protective devices fitted to motorcycles*
- [9] SAE J211-1, *Instrumentation for Impact Test – Part 1: Electronic Instrumentation*
- [10] SAE J211-1, *Instrumentation for Impact Test – Part 2: Photographic Instrumentation*
- [11] SAE J1727, *Calculation Guidelines for Impact Testing*
- [12] SAE J1733, *Sign Convention for Vehicle Crash Testing*
- [13] SETRA n° 97 41 026, *Test Procedure for Restraint Devices for the Safety of Motorcyclists, Service d'Etude Technique Routier et Autoroutier (SETRA)*
- [14] UNE 135900-1, *Standard on the evaluation of performance of the protection systems for motorcyclists on safety barriers and parapets – Part 1: Terminology and test procedures, AENOR*

⁶ Under revision.

⁷ Under revision (merged in the future EN 1317 in development).

⁸ Under revision (merged in the future EN 1317 in development).

⁹ Under revision (merged in the future EN 1317 in development).

SIS-CEN/TS 17342:2019 (E)

- [15] UNE 135900-2, *Standard on the evaluation of performance of the protection systems for motorcyclists on safety barriers and parapets – Part 2: Performance classes and acceptance criteria, AENOR*
- [16] 49 CFR Part 572 Subpart E, Motor vehicle safety — Anthropomorphic Test Devices — Hybrid III Test Dummy, U.S. Department of transportation, Code of Federal Regulations
- [17] 49 CFR Part 572 Subpart M, Motor vehicle safety — Anthropomorphic Test Devices — Side Impact Hybrid 50th Percentile Male, U.S. Department of transportation, Code of Federal Regulations

ARBETSEXEMPLAR SIS/
WORK COPY SIS/

Ordlista

Här har vi samlat de förkortningar som oftast används i standardiseringsssammanhang och förklarat dem kortfattat. Förkortningarna är sorterade i alfabetisk ordning.

CEN	European Committee for Standardization (Comité Européen de Normalisation). Utarbetar Europastandarder för områden som inte täcks av CENELEC.
CENELEC	European Committee for Electrotechnical Standardization (Comité Européen de Normalisation Electro-technique). Utarbetar Europastandarder inom el.
CWA	CEN/CENELEC Workshop Agreement. Tekniskt dokument utarbetat av CEN- och CENELEC-organiserad arbetsgrupp.
EN	Europastandard från CEN/CENELEC.
ETSI	European Telecommunications Standards Institute. De utarbetar Europastandarder inom telekommunikationsområdet.
FDIS	Final Draft International Standard. Slutligt förslag till global standard från IEC eller ISO.
ICS	International Classification for Standards. Ett internationellt klassificeringssystem för standarder.
IEC	International Electrotechnical Commission. Utarbetar internationell standard inom området el.
ISO	International Organization for Standardization. Utarbetar internationell standard inom alla områden utom telekommunikation och elteknik.
ITS	Informationstekniska standardiseringen. Utarbetar och bevakar standardisering inom informationsteknik. En av de svenska medlemmarna i ETSI, European Telecommunications Standards Institute.
ITU	International Telecommunication Union. Utarbetar internationella standarder inom radio och telekommunikation.
IWA	ISO Workshop Agreement. Tekniskt dokument utarbetat av ISO-organiserad arbetsgrupp.
Konsoliderad	En konsoliderad standard har sitt tillägg inarbetat och ersätter tidigare utgåva.
PAS	Publicly Available Specifications. Tekniska dokument inom IEC och ISO.
prEN	Förslag till Europastandard från CEN, CENELEC eller ETSI.
SEK	SEK Svensk Elstandard. Svarar för standardiseringen inom området el i Sverige. Svensk medlem i CENELEC och IEC.
SIS	SIS, Swedish Standards Institute. Svensk medlem i CEN och ISO.
SIS-TR	Technical Report. Teknisk rapport som beskriver resultat av undersökningar eller andra studier.
SIS-TS	Technical Specification. Teknisk specifikation som anger tekniska krav som ska uppfyllas av en produkt, process eller tjänst.
SIS-WA	SIS Workshop Agreement. Överenskommelse som ger regler, riktlinjer eller kännetecken för aktiviteter eller deras resultat.
SIS-WS	SIS Workshop. Standardiseringsprojekt med syfte att snabbt ta fram SIS Workshop Agreement.
SS	Svensk standard. Fastställs av SIS, SEK eller ITS. SS ingår som första led i beteckningen för svensk standard fastställd efter 1 januari 1978.
SS/T1	Tillägg 1 till svensk standard.
SS-EN	Europastandard fastställd som svensk standard.
SS-EN/AC	Rättelse till Europastandard fastställd som svensk standard.
SS-EN/A1	Tillägg 1 till Europastandard fastställd som svensk standard.
SS-EN ISO	Internationell standard från ISO som blivit Europastandard och fastställd som svensk standard.
SS-EN ISO/AC	Rättelse till standard från ISO som blivit Europastandard och fastställd som svensk standard.
SS-EN ISO/A1	Tillägg 1 till standard från ISO som blivit Europastandard och fastställd som svensk standard.
SS-EN ISO/IEC	Internationell standard från ISO/IEC som blivit Europastandard och fastställd som svensk standard.
SS-IEC	IEC-standard fastställd som svensk standard.
SS-ISO	ISO-standard fastställd som svensk standard.
SS-ISO Amd 1	ISO-standard fastställd som svensk standard. Tillägg 1.
SS-ISO/Cor 1	ISO-standard fastställd som svensk standard. Rättelse 1.
WD	Working Draft. Förslag till internationell standard eller Europastandard utarbetade i WG.
WG	Working Group. Arbetsgrupp tillsatt av t. ex. en internationell kommitté.
WI	Work Item. Ärende, en avgränsad arbetsuppgift som avser att resultera i en standard.

Glossary

Here are a number of the abbreviations/acronyms frequently used in standardisation contexts, with brief explanations. The abbreviations are in alphabetical order.

CEN	European Committee for Standardization (Comité Européen de Normalisation). Develops European standards for areas not covered by CENELEC.
CENELEC	European Committee for Electrotechnical Standardization (Comité Européen de Normalisation Electro-technique). Develops European standards in the electricity sector.
CWA	CEN/CENELEC Workshop Agreement. Technical document developed by CEN- and CENELEC-organised working group.
Consolidated	A consolidated standard incorporates its supplement and replaces previous editions.
EN	European standard from CEN/CENELEC.
ETSI	European Telecommunications Standards Institute. Develop European standards in the telecommunications field.
FDIS	Final Draft International Standard. Final proposal for global standard from IEC or ISO.
ICS	International Classification for Standards. An international classification system for standards.
IEC	International Electrotechnical Commission. Develops global standards in the electricity sector.
ISO	International Organization for Standardization. Develops global standards in all areas except telecommunications and electrical technology.
ITS	ITS Information Technology Standardisation. Develops and monitors standardisation in information technology. A Swedish member of the ETSI, European Telecommunications Standards Institute.
ITU	International Telecommunication Union. Develops global standards in radio and telecommunications.
IWA	ISO Workshop Agreement. Technical document developed by ISO-organised working group.
PAS	Publicly Available Specifications. Technical IEC and ISO documents.
prEN	Draft European standards from CEN, CENELEC or ETSI.
SEK	SEK Svensk Elstandard. Develops and monitors standardisation in the electrotechnical sector. Swedish member of the CENELEC and IEC.
SIS	SIS, Swedish Standards Institute. Swedish member of CEN and ISO.
SIS-TR	Technical Report. Technical report describing the results of investigations or other studies.
SIS-TS	Technical Specification. Technical specification describing what requirements a product, process or service must fulfil.
SIS-WA	SIS Workshop Agreement. An agreement setting out rules, guidelines or criteria for activities or their results.
SIS-WS	SIS Workshop. Standardisation project aimed at rapidly developing an SIS Workshop Agreement.
SS	Swedish standard. Established by SIS, SEK or ITS. SS is the first step in all standard classifications to emerge since 1 January 1978.
SS/T1	Supplement 1 to a Swedish standard.
SS-EN	European standard established as Swedish standard.
SS-EN/AC	Correction to the European standard established as Swedish standard.
SS-EN/A1	Supplement to the European standard established as Swedish standard.
SS-EN ISO	International and European standard established as Swedish standard.
SS-EN ISO/AC	Correction to the international and European standard established as Swedish standard.
SS-EN ISO/A1	Supplement to the international and European standard established as Swedish standard.
SS-EN ISO/IEC	International and European standard established as Swedish standard.
SS-IEC	IEC standard established as Swedish standard.
SS-ISO	ISO standard established as Swedish standard.
SS-ISO Amd 1	ISO standard established as Swedish standard, with Amendment 1.
SS-ISO/Cor 1	ISO standard established as Swedish standard, with Correction 1.
WD	Working Draft. Proposed international or European standard developed by the Working Group.
WG	Working Group. Appointed by an international committee or some other body.
WI	Work Item. A delimited task designed to result in a standard.

Slutanvändarlicens

VIKTIGT – LÄS NOGGRANNT IGENOM DESSA VILLKOR INNAN ANVÄNDNING SKER AV DE PRODUKTER SOM TILLHANDAHÅLLS MED DENNA LICENS. GENOM ATT ANVÄNDA PRODUKTERNA GODKÄNNER OCH ACCEPTERAR NI DÄRMED VILLKOREN I DETTA SLUTANVÄNDARLICENSAVTAL.

1. Parter

Detta slutanvändarlicensavtal ("Licensavtal") är ingått mellan SIS och det företag och/eller den person som licensierar standarden som medföljer eller levereras under denna licens ("Kunden").

2. Upphovsrätt till Produkten

Den produkt och dess eventuella metadata som medföljer eller levereras under detta Licensavtal ("Produkten") är skyddad av svensk och internationell upphovsrättslagstiftning och tillhör den eller de upphovsrättsinnehavare som finns angivna på Produkten.

3. Upplåtelse av nyttjanderätt

SIS upplåter till Kunden en icke-exklusiv och icke-överlåtbar nyttjanderätt att använda Produkten enligt följande:

- Om Produkten levereras i pappersform har Kunden rätt att endast för internt bruk inom sin egen verksamhet att använda det exemplar av Produkten som levereras med detta Licensavtal.
- Om Produkten levereras i elektronisk form har Kunden rätt att endast för internt bruk inom sin egen verksamhet installera Produkten på endast en (1) dator, vilken ägs, hyrs eller kontrolleras av Kunden. Kunden har även rätt att flytta Produkten till en annan dator vilken ägs, hyrs eller kontrolleras av Kunden, under förutsättning att Produkten avinstalleras från den första datorn. Produkten får inte användas på två eller flera datorer samtidigt och inte heller i nätverk.

4. Begränsningar i nyttjanderätten

Kunden har inte rätt att under några omständigheter kopiera, anpassa, ändra, förändra, översätta, göra tillägg, uteslutningar och/eller bearbetningar i det material som utgör Produkten, hyra eller leasa ut, sälja, marknadsföra, underlicensiera eller på annat sätt distribuera, sprida eller överlåta Produkten på annat sätt än som uttryckligen anges i detta Licensavtal. Kunden får inte ta bort eller förändra någon upplysning om upphovsrätt, äganderätt och vattenmärkning som finns på Produkten och ansvarar vidare för att de upplysningar om upphovsrätt, äganderätt och vattenmärkning som finns på originalexemplaret av Produkten återges på samtliga kopior (om några) som Kunden har rätt att göra enligt detta Licensavtal. Kunden ansvarar även för att tillse att inte dess anställda ("Användare", "Användaren", "Användarna") eller någon annan än Användarna får åtkomst till eller använder Produktens eller kopia av Produktens metadata.

5. SISs ansvar samt ansvarsbegränsning

SIS ansvarar för att innehållet i den textmassa som Produkten omfattar levereras till Kunden i det skick som den kommit SIS tillhanda. I övrigt levereras Produkten i "befintligt skick" och SIS ansvarar inte för att den information som Produkten förmedlar är korrekt eller fullständig, eller för resultatet av användningen av Produkten. SISs ansvar i enlighet med detta Licensavtal omfattar endast direkta skador och ej indirekta skador såsom exempelvis men inte uteslutande utebliven vinst, intäkt, besparing eller goodwill, förlust på grund av driftavbrott, förlust av data, Kundens eventuella ersättningskyldighet gentemot tredje man eller indirekt skada eller annan följdskada av vad slag det än må vara. I inget fall ska SIS totala skadeståndsansvar enligt detta Licensavtal överstiga ett belopp motsvarande den avgift som Kunden betalat för nyttjanderätten enligt detta Licensavtal.

Kunden ska hålla SIS skadelösa för eventuella

skadeståndsanspråk som påtalas av tredje man avseende Kunden och Användarens användning av Produkten. För den händelse SIS skulle tvingas utge ersättning och skadestånd med anledning av Kundens och Användarens användning av Produkten, skall Kunden omedelbart på anfordran ersätta SIS med ett belopp motsvarande det utgivna.

6. Immateriella rättigheter

Samtliga immateriella rättigheter till Produkterna och dess metadata tillkommer SIS, CEN och ISO och Kunden är medveten om att Kunden och/eller Användaren genom detta Licensavtal inte förvärvar någon som helst rätt till SIS:s, CEN:s och ISO:s upphovsskyddade Produkter och dess metadata, varumärke, domännamn, firmanamn, kännetecken, know-how, och andra immateriella rättigheter som tillhör SIS, CEN och ISO.

Kunden äger inte rätt att utan SISs skriftliga samtycke använda och marknadsföra SIS:s, CEN:s och ISO:s varumärken, logotyper, domännamn, produktbenämningar och firmanamn.

Kunden skall vidta alla de rättigheter som SIS rimligen kan kräva och vara SIS behjälplig för att SIS ska kunna upprätthålla giltigheten och genomförbarheten av SIS immateriella rättigheter under giltighetstiden för detta Licensavtal.

7. Intrång i immaterialrätt

Om det, enligt SIS, föreligger risk för att krav avseende intrång i tredje mans immateriella rättigheter kan komma att ställas på grund av användningen av Produkterna, har SIS rätt att på egen bekostnad (i) utverka rätt för Kunden att fortsätta med användning av Produkten, (ii) förändra eller ersätta Produkten eller del därav med andra produkter i syfte att undvika sådant krav, eller (iii) stoppa Kundens användning av Produkten och återbetala de avgifter som erlagts för den tid då utnyttjande av Produkten inte kunnat ske.

SIS ansvarar inte gentemot Kunden för krav som kunde ha undvikits om Kunden accepterat ersättningsprodukt eller om användningen av Produkten stoppats.

Kunden skall utan dröjsmål informera SIS om intrång eller misstänkt intrång i SIS alla immateriella rättigheter som finns uppräknade i detta Licensavtal och som inte är begränsat till de marknader där Kunden är verksam på.

8. Personuppgiftsbehandling

SIS lagrar och behandlar Användarnas persondata i elektronisk form och i pappersform. Detta gör SIS för fullgörande av detta Licensavtal, för att fullgöra SISs skyldighet enligt lag eller annan författning, för fakturerings-, betalnings- och bokföringsändamål, för marknadsföringsändamål, för reklamationshantering, för kundservice, säkerhets, sekretess- och administrationsfrågor, kvalitetsarbete, affärsutveckling för bl.a. kund- och marknadsanalyser samt för statistiska ändamål. SIS kan komma att överföra personuppgifter som härrör till Kunden och Användarna utanför SIS och till ett annat land för fullgörande av detta Licensavtal. SIS säkerställer att en adekvat skyddsnivå enligt gällande personuppgifts-regelverket uppfylls vid en sådan överföring av personuppgifterna utanför SIS och till ett annat land. Behandling av personuppgifterna kommer att ske så länge personuppgifterna behövs för de aktuella ändamålen. Med personuppgifter avses all slags information som direkt

eller indirekt kan hänföras till en fysisk person som är i livet räknas enligt Personuppgiftslagen som personuppgifter. Även bilder och ljudupptagningar på individer som behandlas i dator kan vara personuppgifter även om inga namn nämns.

Kunden och dess Användare har rätt att kostnadsfritt en gång per kalenderår, efter skriftligt undertecknad ansökan av behörig Användare hos Kunden ställd till SIS, Box 45443 SE-104 31 Stockholm få besked om vilka personuppgifter som SIS behandlar som kan härledas till den behöriga Användaren ifråga, vad syftet med personuppgiftsbehandlingen är och hur SIS behandlar dennes persondata. Behörig Användare hos Kunden har också rätt att begära rättelse i fråga om dennes personuppgifter eller kräva att SIS skall radera dennes personuppgifter. Behörig Användare hos Kunden har också rätt att invända mot SISs behandling av dennes personuppgifter och inge klagomål till Datainspektionen.

9. Export

Kunden äger inte rätt att exportera eller reexportera Produkten eller del därav, tillhörande information eller teknologi i strid med gällande svensk och annan tillämplig exportlagstiftning.

10. Avtaistid och uppsägning

Detta Licensavtal gäller tills vidare. Kunden har rätt att säga upp Licensavtalet när som helst. SIS har rätt att kan säga upp Licensavtalet till omedelbart upphörande om Kunden bryter mot bestämmelse i Licensavtalet. Då Licensavtalet upphör ska Kunden omedelbart upphöra med användningen av Produkten och förstöra samtliga kopior av denna.

11. Tillämplig lag

Svensk lag gäller för detta Licensavtal och tvister ska avgöras genom förfarande vid svensk domstol.

12. Övriga bestämmelser

Detta Licensavtal utgör en fullständig reglering av vad som avtalats mellan parterna avseende användningen av Produkten och ersätter samtliga tidigare skriftliga eller muntliga avtal, utfästelser eller överenskommelser parterna emellan. Ändring i Licensavtalet kan endast ske genom skriftligen upprättad handling vilken undertecknats av SIS. Om en bestämmelse i Licensavtalet skulle förklaras ogiltig av någon anledning, ska Licensavtalet revideras endast i sådan omfattning som är nödvändigt för att göra Licensavtalet giltigt, och sådan revidering ska (i) inte påverka giltigheten av den ogiltigförklarande delen under andra omständigheter, eller (ii) påverka övriga delar av Licensavtalet.

SIS äger rätt att fritt överlåta samtliga sina rättigheter och skyldigheter enligt detta Avtal till moderföreningen SIS Ideell Förening.

End user license

IMPORTANT - READ CAREFULLY THROUGH THESE TERMS AND CONDITIONS BEFORE USING THE PRODUCTS PROVIDED UNDER THIS LICENSE. BY USING THE PRODUCTS, YOU APPROVE AND ACCEPT THE TERMS AND CONDITIONS OF THIS END USER LICENCE AGREEMENT.

1. The Parties

This end user licence agreement ("the License Agreement") has been entered into between SIS and the company and/or the person who licenses the standard that is included or delivered under this License Agreement ("the Customer").

2. Copyright to the Product

The product and any associated metadata that is included or delivered under this License Agreement ("the Product") is protected by Swedish and international copyright law and belongs to the copyright holder(s) stated for the Product.

3. Granting of right of use

SIS grants the Customer a non-exclusive and non-transferable right to utilise the Product as follows:

(a) If the Product is delivered in paper format, the Customer is entitled to use the copy of the Product provided within this License Agreement solely for internal use within his/her own business.

(b) If the Product is delivered in electronic format, the Customer is entitled to install the Product provided within this License Agreement on one (1) computer, which is owned, leased or controlled by the Customer, solely for internal use within his/her own business. The Customer also has the right to move the Product to another computer that is owned, leased or controlled by the Customer, provided that the Product is uninstalled from the first computer. The Product may not be used on two or more computers at the same time, nor in a network.

4. Limitations to the right of use

The Customer may not, in any event, copy, adapt, modify, alter, translate, make additions to, exclusions and/or process the material contained in the Product and/or copies of the Product, rent or lease, sell, market, sublicense or otherwise distribute, disseminate or transfer the Product and/or copies of the Product produced in any other way than as explicitly stated in this License Agreement. The Customer may not remove or change any information on copyright, proprietary rights and watermarks contained in the Product and the Customer is also responsible for ensuring that the copyright, proprietary rights and watermarks contained in the original copy of the Product are reproduced on all copies (if any) that the Customer is entitled to make under this License Agreement. The Customer is also responsible for ensuring that his/her employees ("User", "the User", "the Users") or any one other than the Users do not have access to or use the metadata of the Product or copy of the Product.

5. Limitation of liability

SIS is only liable for ensuring that the content of the text included in the Product is delivered to the Customer in the condition in which it was received by SIS. Otherwise, the Product is delivered "as is" and SIS is not responsible for the accuracy or completeness of the information provided in the Product or for the result of the use of the Product.

SIS's liability in accordance with this Agreement includes only direct damages and not indirect damage such as loss of profit, revenue, savings or goodwill, loss due to operational disruptions, loss of data, any liability for compensation on the part of the Customer in relation to third parties or indirect damage or other consequential loss of

any kind. Under no circumstances shall SIS total liability for damages under this License Agreement exceed an amount corresponding to the fee paid by the Customer for the right of use under this License Agreement.

The Customer shall indemnify SIS for any damages claimed by third parties in regard to the Customer and the User's use of the Product. In the event that SIS would have to pay compensation and damages due to the Customer's and the User's use of the Product, the Customer shall on request immediately reimburse the amount in question to SIS.

6. Intellectual property rights

All intellectual property rights to the Products and their metadata belong to SIS, CEN and ISO, and the Customer is aware that the Customer and/or the User do not acquire any right through this License Agreement to copyright protected products belonging to SIS, CEN and ISO nor to their metadata, trademark, domain name, company name, characteristics, know-how, or to other intellectual property rights of SIS, CEN and ISO.

The Customer is not entitled to use and market trademarks, logos, domain names, product names and company names belonging to SIS, CEN and ISO without the written consent of SIS.

7. Infringement of intellectual property rights

If, in the view of SIS, there is a risk that claims for infringement of third party intellectual property rights may be made as a result of the use of the Products, SIS has the right at its own expense (i) to exercise the right for the Customer to continue using the Product, (ii) change or replace the Product or part thereof with other products in order to avoid such a claim, or (iii) stop the Customer's use of the Product and refund the fees paid for the time when utilisation of the Product could not be made.

SIS are not liable to the Customer for any claims that could have been avoided if the Customer had accepted a replacement product or if the use of the Product was terminated.

The Customer shall notify SIS without delay of any infringement or suspected infringement of all intellectual property rights belonging to SIS and SIS listed in this License Agreement, and which are not limited to the markets in which the Customer operates.

8. Personal data processing

SIS process and store the User's personal data in electronic and in paper format. SIS does this for fulfilment of the terms of this License Agreement, to fulfil SIS's obligations by law and other mandatory obligations, for the purposes of billing, payment and accounting, for the purposes of marketing, for the handling of claims, for customer services, for matters relating to confidentiality and administration, quality management, business development - including for customer and market analyses, and for statistical purposes. SIS may transfer personal data belonging to the Customer and Users outside SIS and to other organizations and countries. SIS ensures that an adequate level of security in accordance with prevailing personal data legislation is met in cases of the transfer of data to other countries. Personal data will be processed as long as the personal data is required for the purpose in question. Personal data, according to the Swedish Personal Data Act, refers to all types of information that can directly or indirectly be related to a

living being. Even images and audio recordings of individuals processed on computers may be regarded as personal data regardless whether or not names are mentioned.

The Customer and its Users are entitled to, once a calendar year and free of charge, upon written request from the authorized User at the Customer to SIS, Box 45443 SE-104 31 Stockholm, to obtain information on what personal data SIS processes that may be related to the authorized User in question, the purpose of processing this personal data, and how the User's personal data is treated by SIS. Authorized Users at the Customer are also entitled to request corrections to their personal data, or demand that SIS delete their personal data. Authorized Users at the Customer are also entitled to have their personal data transferred to another company or organization (so-called data portability). Authorized Users at the Customer are also entitled to object to SIS's treatment of their personal data and submit a complaint to the Swedish Data Protection Authority.

9. Export

The Customer does not have the right to export or re-export the Product or part thereof, related information or technology in breach of applicable Swedish and other applicable export legislation.

10. Agreement term and termination

This Licence Agreement applies until further notice. The Customer has the right to terminate the Licence Agreement at any time. SIS has the right to terminate the License Agreement with immediate effect if the Customer is in breach of any provision in the License Agreement. Upon termination of the License Agreement, the Customer shall immediately cease the use of the Product and destroy all copies thereof.

11. Applicable law

Swedish law applies to this License Agreement and any disputes shall be settled in a Swedish court in Stockholm.

12. Other provisions

This License Agreement constitutes full regulation of that which has been agreed between the Parties regarding the use of the Product and supersedes all previous written or verbal contracts, declarations or agreements between the Parties. Changes to the License Agreement can only be made by written document signed by SIS. If a provision in the License Agreement should be declared invalid for any reason, the License Agreement shall be revised only to the extent necessary to make the License Agreement valid and such revision shall (i) not affect the validity of the part declared invalid in other circumstances, or (ii) affect other parts of the License Agreement.

SIS is entitled to freely transfer all of its rights and obligations under this Agreement to the parent association SIS Ideell Förening.

SIS, Swedish Standards Institute och SEK Svensk Elstandard leder arbetet med standardisering i Sverige. Tillsammans med företag och organisationer jobbar vi med att förenkla, förbättra, kvalitetssäkra och skapa gemensamma standarder. SIS kunder har inflytande i internationell standardisering genom CEN i Europa och ISO globalt. SEK samordnar svensk medverkan i CENELEC i Europa och IEC globalt.

Du kan få dina standarder i olika format och media, detta är ett av dem. SIS är störst i Norden på att leverera standarder och allt som rör dess tillämpning. En tryckt standard från SIS är alltid tryckt på miljövänligt papper.

Vill du veta mer om vårt utbud och tjänster? Ring oss på 08-555 523 10 eller besök oss på www.sis.se

The Swedish Standards Institute (SIS) and SEK Svensk Elstandard share principal responsibility for standardisation in Sweden. Working with various agencies, enterprises and organisations, we seek to simplify, to introduce improvements, to secure quality and to establish common standards. SIS customers influence today's international standardisation work via CEN in Europe and ISO globally. SEK coordinates Swedish participation in CENELEC in Europe and in the IEC at the global level.

You can obtain your standards in different formats and in different media – this is just one of them. SIS is the leading supplier in the Nordic area of standards and all related applications. Printed standards from SIS are always printed on eco-friendly paper.

Would you like to know more about our range of products and services? Phone us at +46 8 555 523 10 or visit us at www.sis.se

ARBETSEXEMPLAR SIS/
WORK COPY SIS/